

# Combination Strainer Valve



Y-Strainer • Isolation Ball Valve • 20 Mesh Strainer with Union and PT Port • 600 WOG



Terminator Y

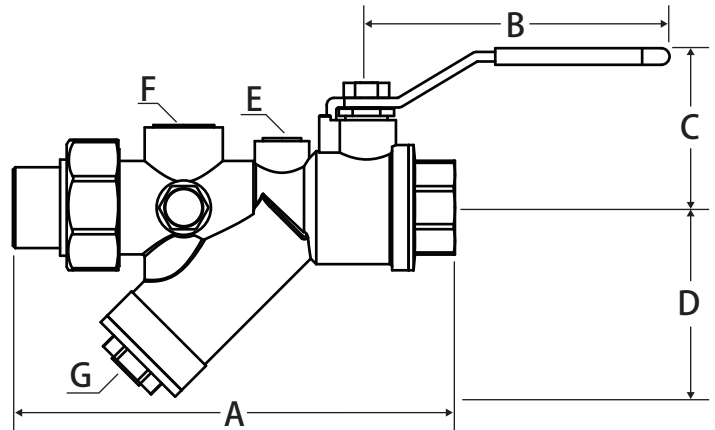

← DIRECTION OF FLOW

## Features

- Three additional accessory tap
- Triple sealing stem with 2 Viton® o-rings and Teflon® seal
- Blow out proof stem
- 100% leak tested

## Pressure and Temperature Rating

- 600 WOG
- 325°F Max

## Smart Part Number Ordering Guide

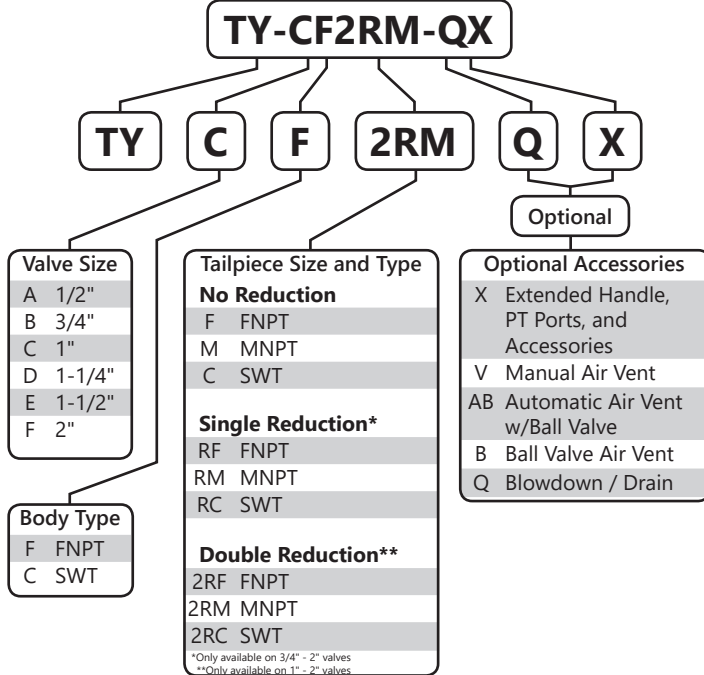

## Material Specifications

Part	Material
Body	Brass -CW617N
End Connection	Brass -CW617N
Ball	Chrome Plated Brass -CW617N
Seat (2)	PTFE
Stem	Brass -CW617N
Packing	PTFE
Stem O-ring (2)	Viton®
Packing Gland	Brass -CW617N
Handle	Steel - Zinc Plated
Handle Nut	Brass -CW617N
Service Cap	Brass -CW617N
Service Cap O-ring	Viton®
Strainer	304 Stainless Steel
Union Gasket	EPDM
Tail Piece	Brass -CW617N
Union Nut	Brass -CW617N

## Dimensions

Size	A*	B	C	D	E	F	G	Cv
1/2"	5.03	3.40	1.70	1.60	0.25	0.50	0.25	5.50
3/4"	5.88	3.40	1.80	2.40	0.25	0.50	0.25	9.00
1"	6.25	3.40	1.80	2.40	0.25	0.50	0.25	9.00
1-1/4"	7.88	4.40	2.50	3.50	0.25	0.75	0.25	28.00
1-1/2"	8.00	4.40	2.50	3.50	0.25	0.75	0.25	28.00
2"	10.31	5.50	3.50	4.50	0.25	0.75	0.50	32.00

\*Length is for a SWT x FNPT valve, additional dimensions available upon request



**WARNING:** This product can expose you to chemicals including lead, which is known to the State of California to cause cancer, and lead, which is known to the State of California to cause birth defects or other reproductive harm. For more information go to [www.P65Warnings.ca.gov](http://www.P65Warnings.ca.gov).