

Combination Strainer Valve

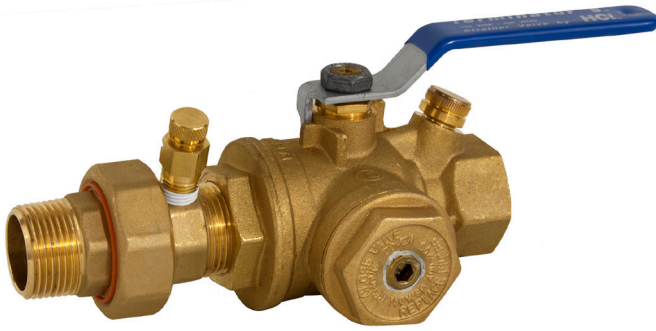

Integrated Isolation Ball Valve and Strainer • Union • 400 WOG



Terminator S

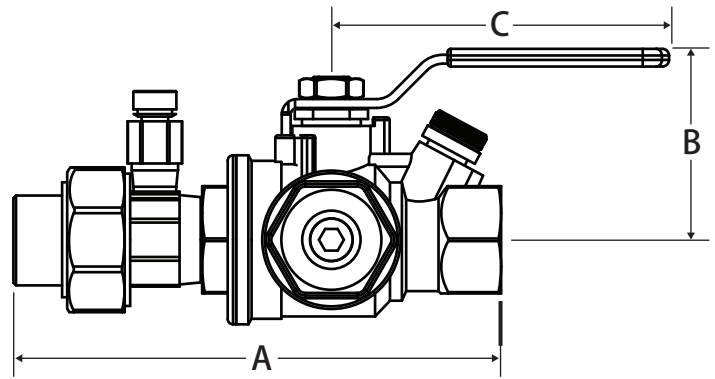

← **DIRECTION OF FLOW**

Features

- Integrated back flush
- Pressure / temperature (PT) test ports
- Two additional accessory tap
- Triple sealing stem with 2 Viton® o-rings and Teflon® seal
- Blow out proof stem
- 100% leak tested
- Made in Italy
- Leakproof stem - Lifetime warranty

Pressure and Temperature Rating

- 400 WOG
- 250°F Max

Smart Part Number Ordering Guide

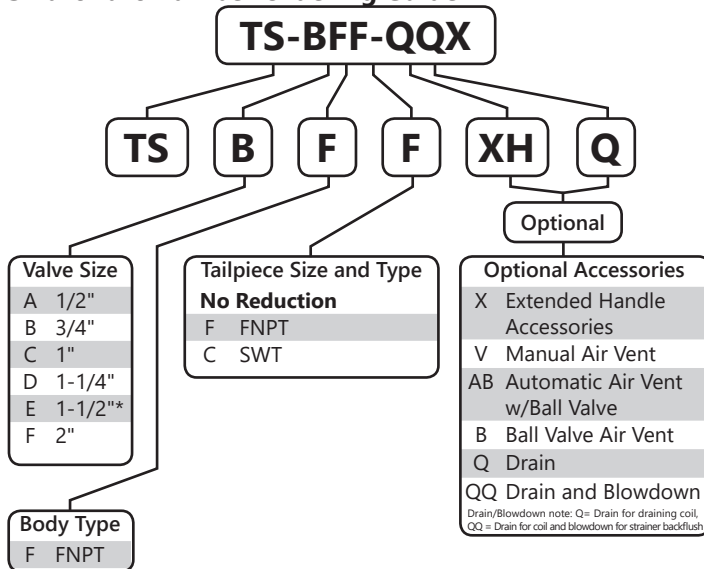

*Does not have back flush feature

Material Specifications

Part	Material
Body	Brass - CW602N
End Connection	Brass - CW602N
Ball	Chrome Plated Brass - CW602N
Seat (2)	Virgin PTFE
Stem	Brass - CW602N
Packing	Virgin PTFE
Stem O-ring (2)	Viton®
Packing Gland	Brass - CW614N
Handle	Steel - Geomet® Plated
Handle Nut	Steel - Geomet® Plated
Filter Basket	304 Stainless Steel
C-Clip Retainer	304 Stainless Steel
Body Insert	Brass - CW602N
Auxiliary Seat	Virgin PTFE
Cap	Brass - CW602N
O-ring	Viton®
Back Flush Plug	Brass - CW614N
Back Flush O-ring	Viton®
Back Flush Cap	Brass - CW614N
Union	(See Terminator U Spec Sheet)

Dimensions

Size	A*	B	C	Cv
1/2"	5.70	2.40	4.75	13.02
3/4"	5.70	2.40	4.75	13.02
1"	6.50	2.60	4.75	16.28
1-1/4"	7.38	3.23	5.88	24.20
1-1/2"	7.68	3.50	5.88	39.63
2"	9.44	3.15	8.13	74.85

*Length is for a FNPT x FNPT valve, additional dimensions available upon request



WARNING: This product can expose you to chemicals including lead, which is known to the State of California to cause cancer, and lead, which is known to the State of California to cause birth defects or other reproductive harm. For more information go to www.P65Warnings.ca.gov.