

# Automatic Balancing Valve



Automatic Flow Limiter • Wafer Connection • 400 WOG



Terminator A Wafer x Wafer

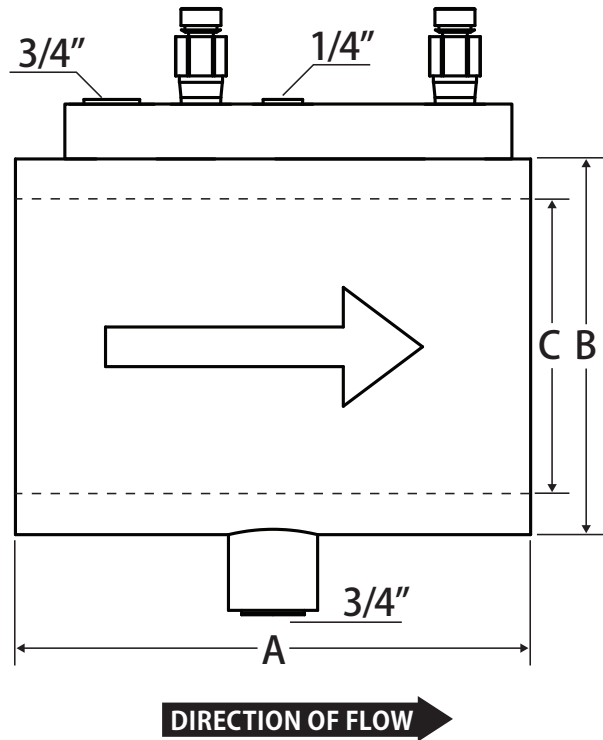

## Features

- 2-50 PSID operating range
- +/- 5% Accuracy
- Two pressure / temperature (PT) test ports
- Location tag
- Two additional accessory tap

## Pressure and Temperature Rating

- 2-1/2" - 6": 426 WOG
- 8" - 12": 400 WOG
- 350°F Max

## Smart Part Number Ordering Guide

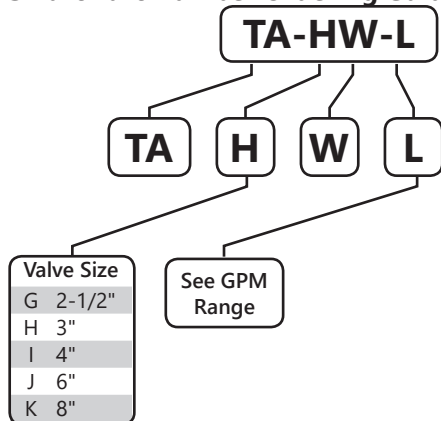

## Material Specifications

Part	Material
Body (2-1/2" - 6")	Cast Iron
Body (8" - 12")	Carbon Steel
Balancing Cartridge	Brass, Stainless steel, EPDM
Cartridge C-Clip Retainer	Carbon Steel

## Dimensions

Size	A	B	C
2-1/2"	6.26	4.875	2.56
3"	6.26	5.875	3.34
4"	6.26	6.875	4.86
6"	6.26	8.750	7.10
8"	6.26	11.00	9.26

## GPM Range

Size	Flow Rate	Low or High
2-1/2"	80	L
2-1/2"	120	H
3"	135	L
3"	170	H
4"	270	L
4"	340	H
6"	540	L
6"	680	H
8"	945	L
8"	1190	H



**WARNING:** This product can expose you to chemicals including lead, which is known to the State of California to cause cancer, and lead, which is known to the State of California to cause birth defects or other reproductive harm. For more information go to [www.P65Warnings.ca.gov](http://www.P65Warnings.ca.gov).