

Metering Station

Fixed Orifice • Flange x Groove Connection • Class 150

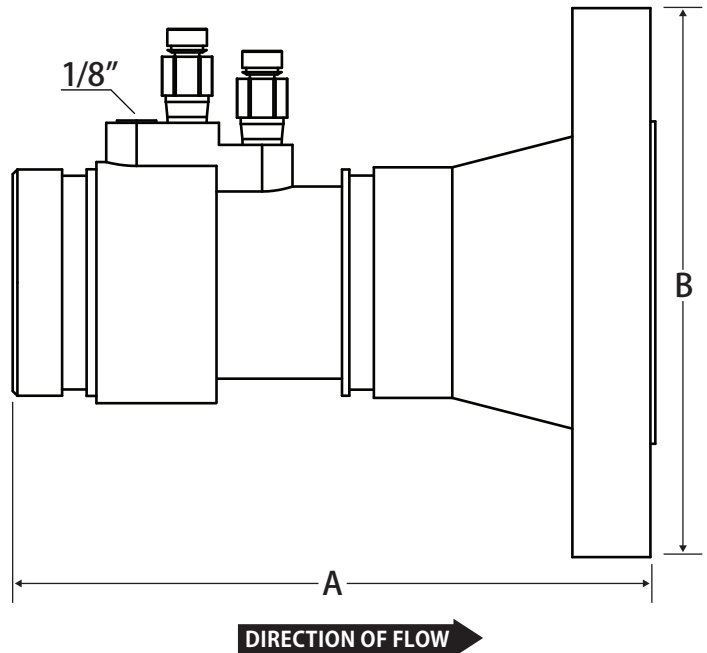

Terminator MS Flange x Groove



Features

- +/- 1% Accuracy
- Two pressure / temperature (PT) test ports
- Location tag
- Additional accessory tap
- Class 150 Flange
- 100% leak tested
- 5 straight pipe diameters are required upstream of metering station
- 2-1/2 straight pipe diameters are required downstream of metering station
- See end of catalog for pressure drop charts

Pressure and Temperature Rating

- 200 WOG
- 225°F Max

Smart Part Number Ordering Guide

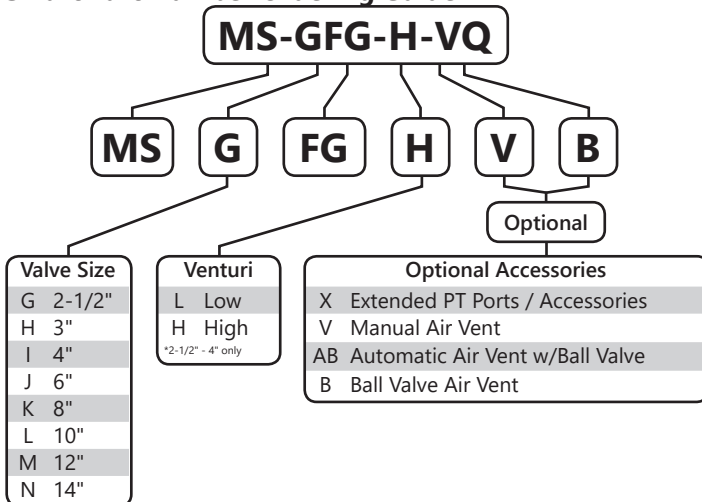

Material Specifications

Part	Material
Venturi Body	Carbon Steel - ASTM 126
Flange	Carbon Steel - ASTM 126

Dimensions

Size	A	B
2-1/2"	10.2	7.0
3"	10.5	7.5
4"	11.5	9.0
6"	13.5	11.0
8"	15.9	13.5
10"	20.6	16.0
12"	25.8	19.0



WARNING: This product can expose you to chemicals including lead, which is known to the State of California to cause cancer, and lead, which is known to the State of California to cause birth defects or other reproductive harm. For more information go to www.P65Warnings.ca.gov.

Pressure Drop Chart



Terminator MS (2-1/2" - 4")

Permanent pressure loss is 6% of the differential pressure

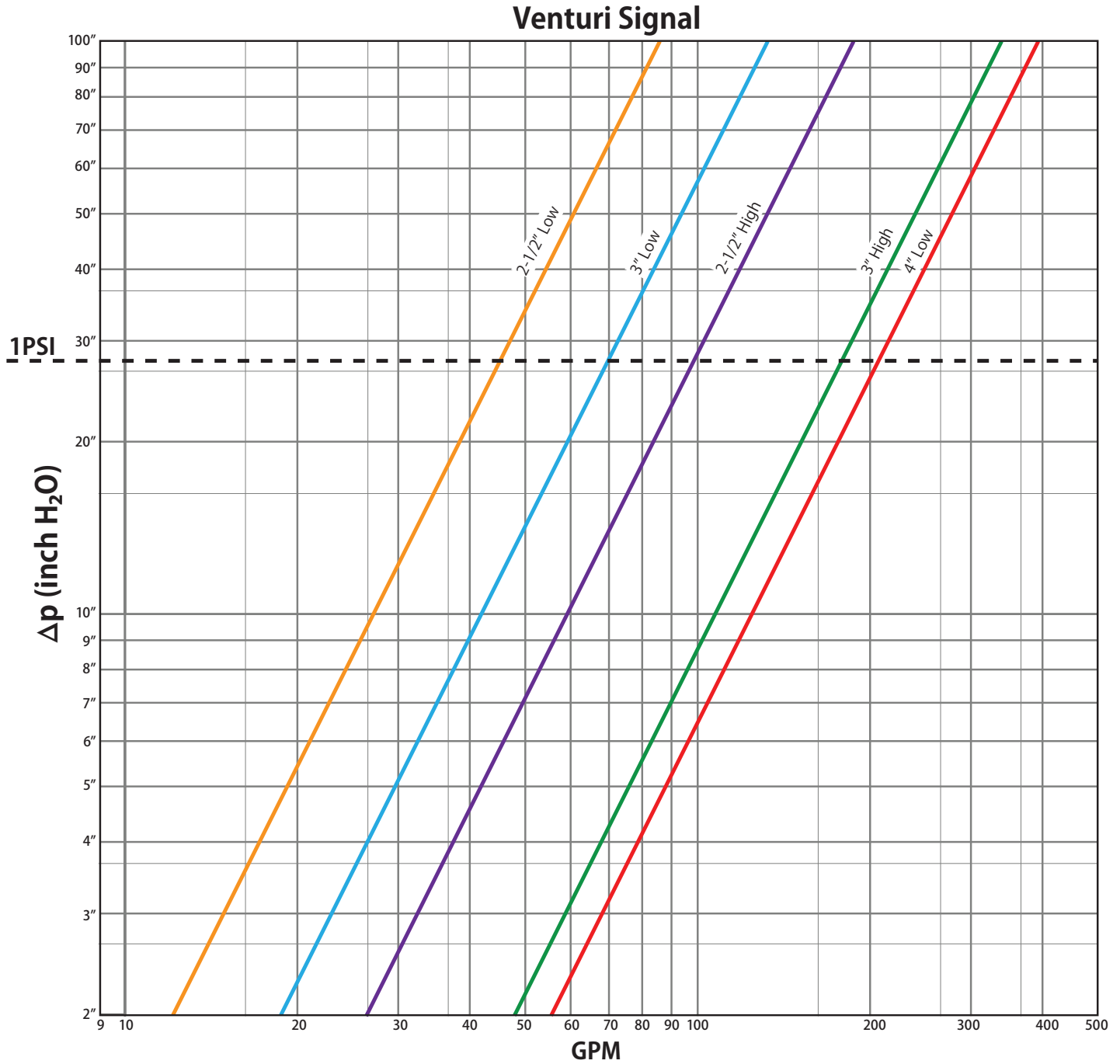

Pressure Drop Chart



Terminator MS (6" - 12")

Permanent pressure loss is 6% of the differential pressure

