

Pressure Independent Control Valves

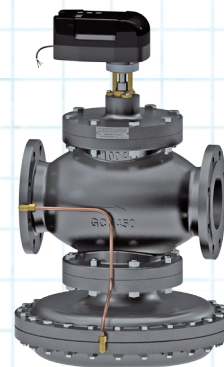
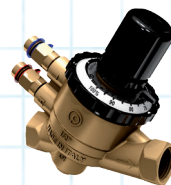
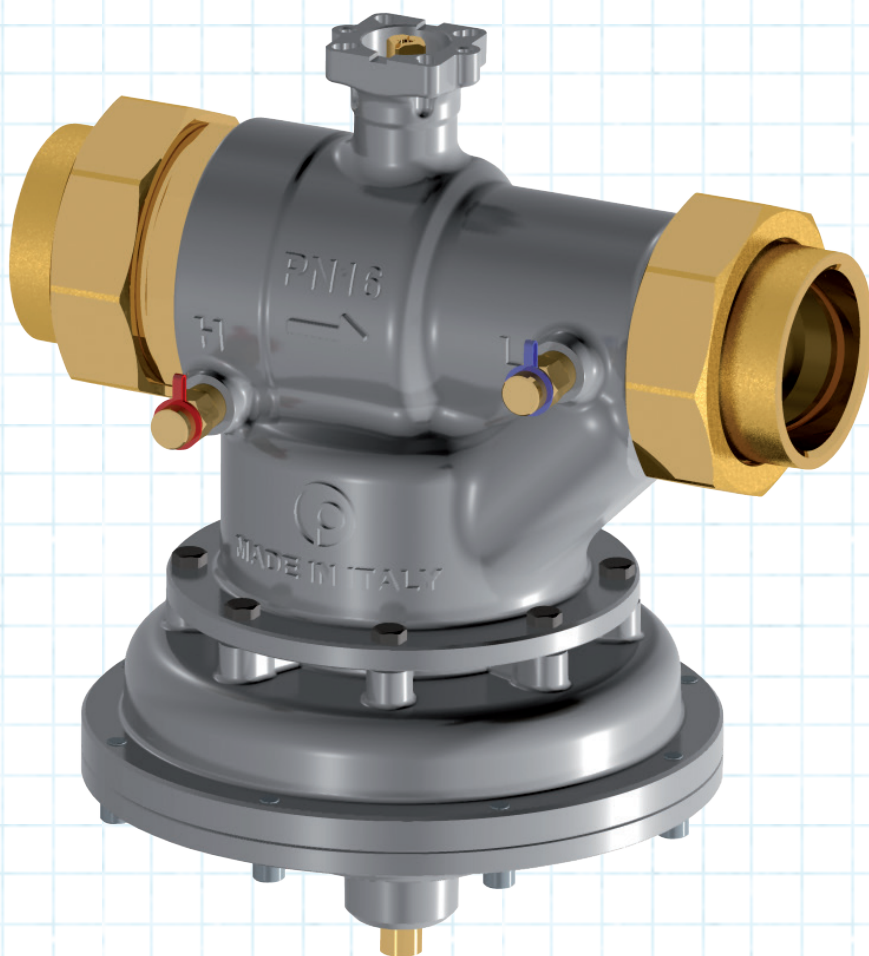

Pressure Independent Control Valve

The **Terminator PICV** Pressure Independent Control Valve is a combined constant flow limiter and full stroke, full authority, equal percentage temperature control valve.

The Terminator PICV is suitable for use in variable and constant temperature systems and may be used as a constant flow limiter in constant volume systems (without an actuator head) or as a true PICV in variable volume systems.

Operating principles

The **Terminator PICV** valve is made up of three main parts:

1. differential pressure regulator
2. regulating valve for flow adjustment
3. flow pre-setting knob

Differential pressure regulator

The differential pressure regulator is the heart of the pressure independent control valve. By keeping a constant differential pressure across the control valve, constant flow and full authority temperature control can be achieved. Incoming pressure P1 is transmitted to the top face of the diaphragm, while outgoing pressure P3 is transmitted to the underside of the same diaphragm. A constant effective differential pressure is maintained between P2 and P3. As P1 increases relative to P3, it acts on the diaphragm closing the shutter (A) against a seat (B), thereby lowering the effective differential pressure. As P1 decreases relative to P3, the diaphragm acts to open the shutter (A) from the seat (B), thus increasing the effective differential pressure. The diaphragm acts against a spring in order to balance the pressure control and stop the diaphragm oscillating.

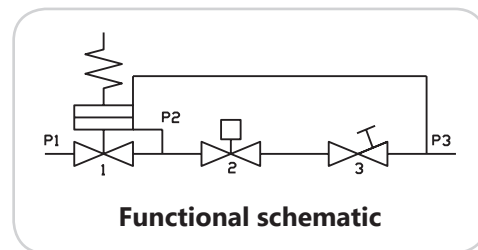
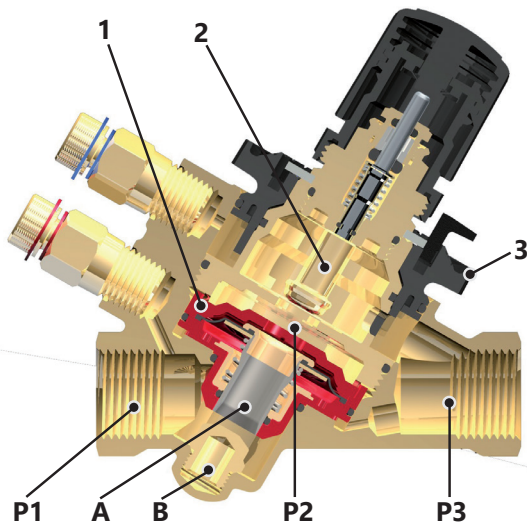

Regulation valve

Water flow through a valve varies as a function of the area of passage and the pressure differential across that valve. Due to the incorporation of the differential pressure regulator, the differential across the valve seats P2 – P3 is constant, meaning that flow is now only a function of area of passage.

Setting and maintaining a flow rate value is also possible. The control valve presents an equal percentage characteristic.

Adjustment knob

The maximum flow can be preset, choking the outlet section of the control valve, by using the graduated adjustment knob.

The percentage value, indicated on the scale, matches the maximum flow rate percentage. This value can be changed by turning the adjustment knob until it reaches the selected position (matching the percentage indicated on the scale). A locking mechanism stops the valve set values from being changed inadvertently.

A PICV replaces a traditional control valve on a terminal unit (FCU, CB, AHU). It limits flow rate irrespective of pressure and offers the possibility to modulate the flow rate (according to room temperature) by using a proportional thermostat or BMS system.

Dynamic curve

Provides constant flow at any pump head

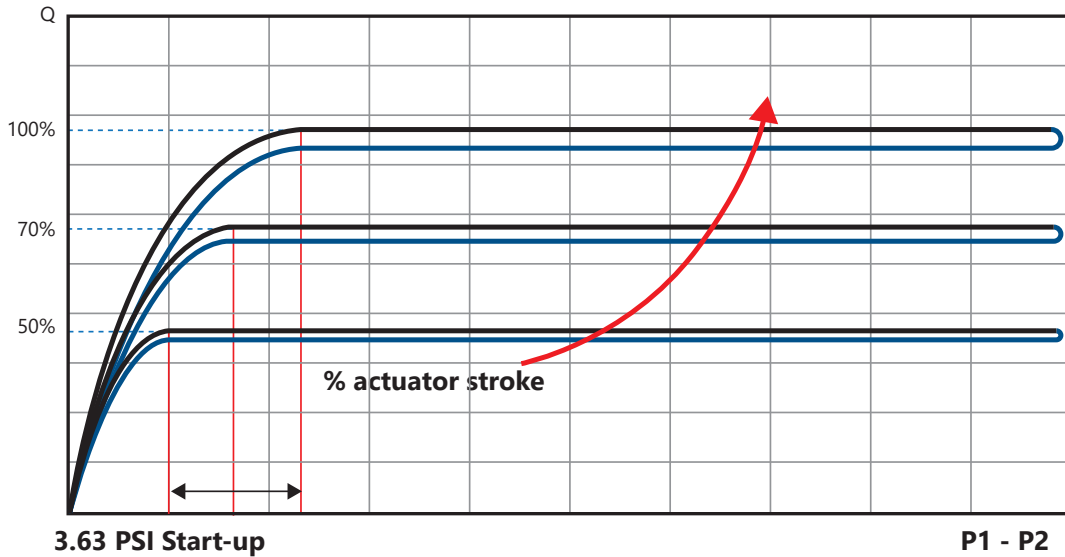

The dynamic curve can be initially limited using a graduated pre-setting device; then the flow can be further adjusted by means of the control valve, which is positioned by the actuator.

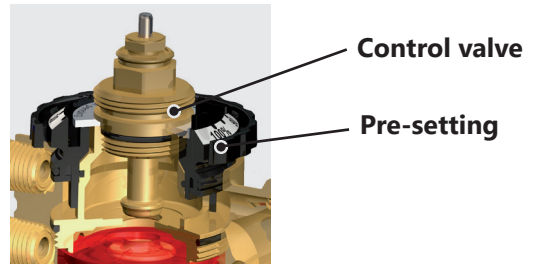

Control curve

Changes design flow according to control logic of BMS

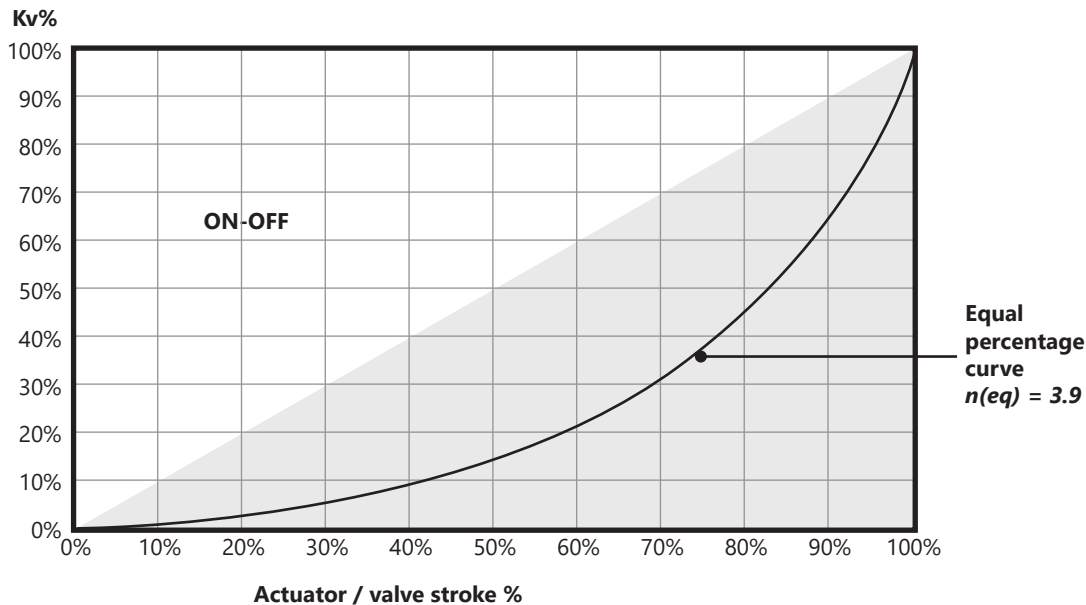

91 Series

1/2" thru 3/4"



Compact version

Available with FIP x FIP threads

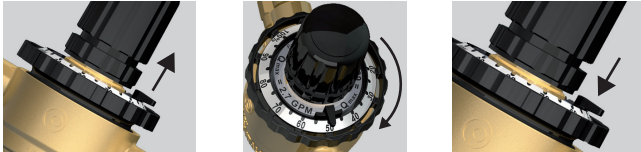

Manual flow setting device

93 Series

3/4" thru 1-1/4"



Flexible version

Available with double union ends (male, female, or sweat)



Removable diaphragm for flushing, maintenance and trouble shooting

FLOW RATE

Flow rate can be adjusted without taking the actuator off the valve.



DIAPHRAGM

Diaphragm is one solid piece, resulting in easier handling and maintenance.

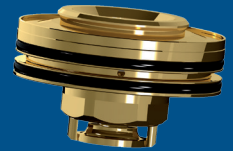

Actuator compatibility chart



Thermal electric

On/Off

Proportional

24V

120V



Electromotive

Floating

Proportional

24V

120V

Actuator compatibility chart



Thermal electric

On/Off

Proportional

24V

120V



Electromotive

Floating

Proportional

24V

120V

85 Series

1-1/4" thru 2"

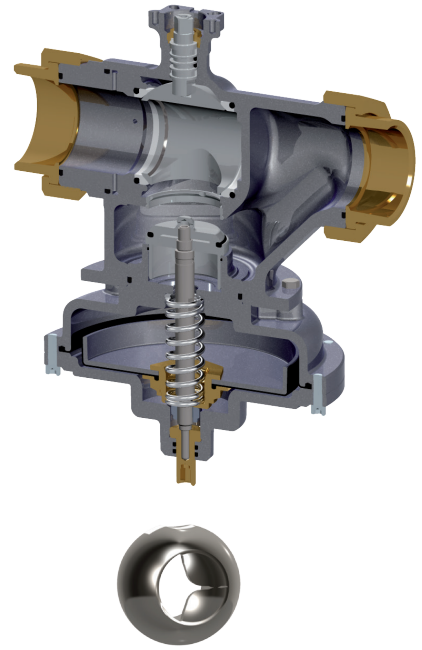
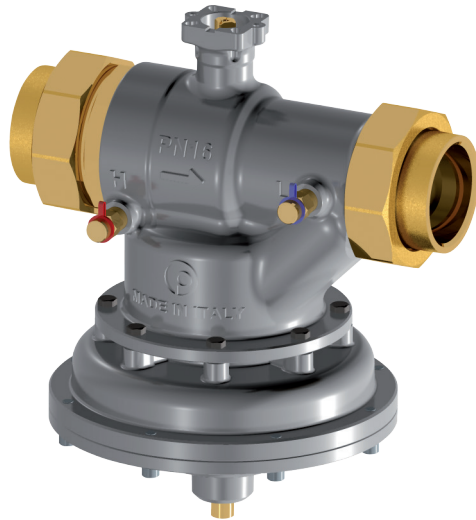

Unique in the world: integrated flushing bypass mode

Solid and reliable characterized control ball valve
Double union end connection for total flexibility

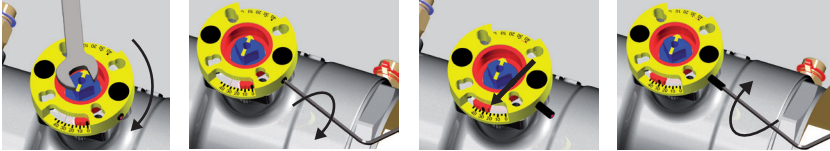

Manual flow setting device

Characterized profile / full port profile

OPERATION MODE

Control valve is fully open, controlling the flow through a profiled ball and a 90° rotating actuator.

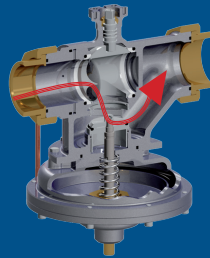

FLUSHING MODE

Control valve is rotated by 180°, with a profiled opening outside of the flow path. The valve now has full port passage, allowing twice the maximum flow, for proper flushing and cleaning.

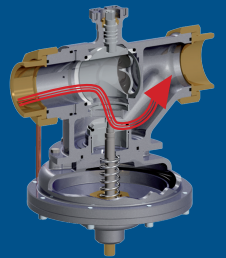

Actuator compatibility chart



90° Rotary actuator
24V Proportional



90° Rotary actuator floating
24V
110V



90° Rotary actuator spring return
24V
110V

94F Series

2" thru 6"

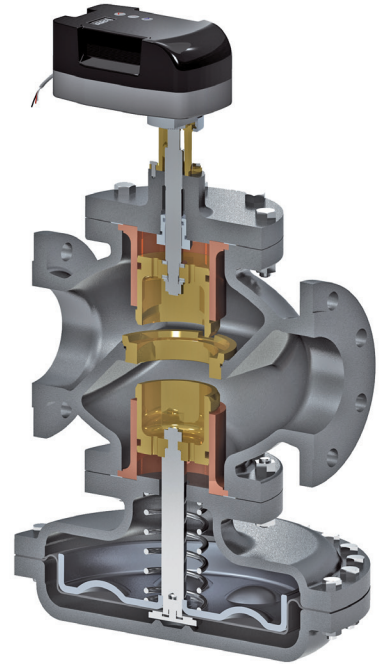

FEATURES

Intelligent actuator with user-friendly interface for flow setting.
Selectable linear or equal percentage control characteristic.
Ductile Iron body.
Flanged connections to ANSI standards.
Maximum flow up to 660.43 GPM.

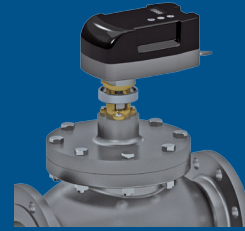

SMART Actuator



Flow rate can be easily set from the on-board user interface.
Compatible with most commonly used control signals:

Proportional (current or voltage control)

3 point floating

ON/OFF

4 – 20 mA position feedback signal as default option, for total remote management.



PRODUCT		91/93/85 SERIES						94F SERIES					
Size	mm	15	20	25	32	40	50	50	65	80	100	125	150
	in	1/2"	3/4"	1"	1 1/4"	1 1/2"	2"	2"	2 1/2"	3"	4"	5"	6"
Flow range (GPM)	Qmin	.20	.44	.97	1.19	3.96	14.53	8.81	8.81	13.21	24.22	39.63	39.63
	Qmax	3.43	9.69	11.89	26.42	39.63	79.25	88.06	132.09	132.09	242.16	528.34	660.43
Fluid	Cold/hot water												
Temp. (fluid)	41 ~ 248 °F												
Differential pressure range	2.90 ~ 87 PSI						4.35 ~ 87 PSI						
Material	Body	Brass / Ductile iron						Ductile Iron					
	Diaphragm	EPDM											
Connection	Threaded / union end						Flanged						
Max operating static pressure	360 PSI						230 PSI						

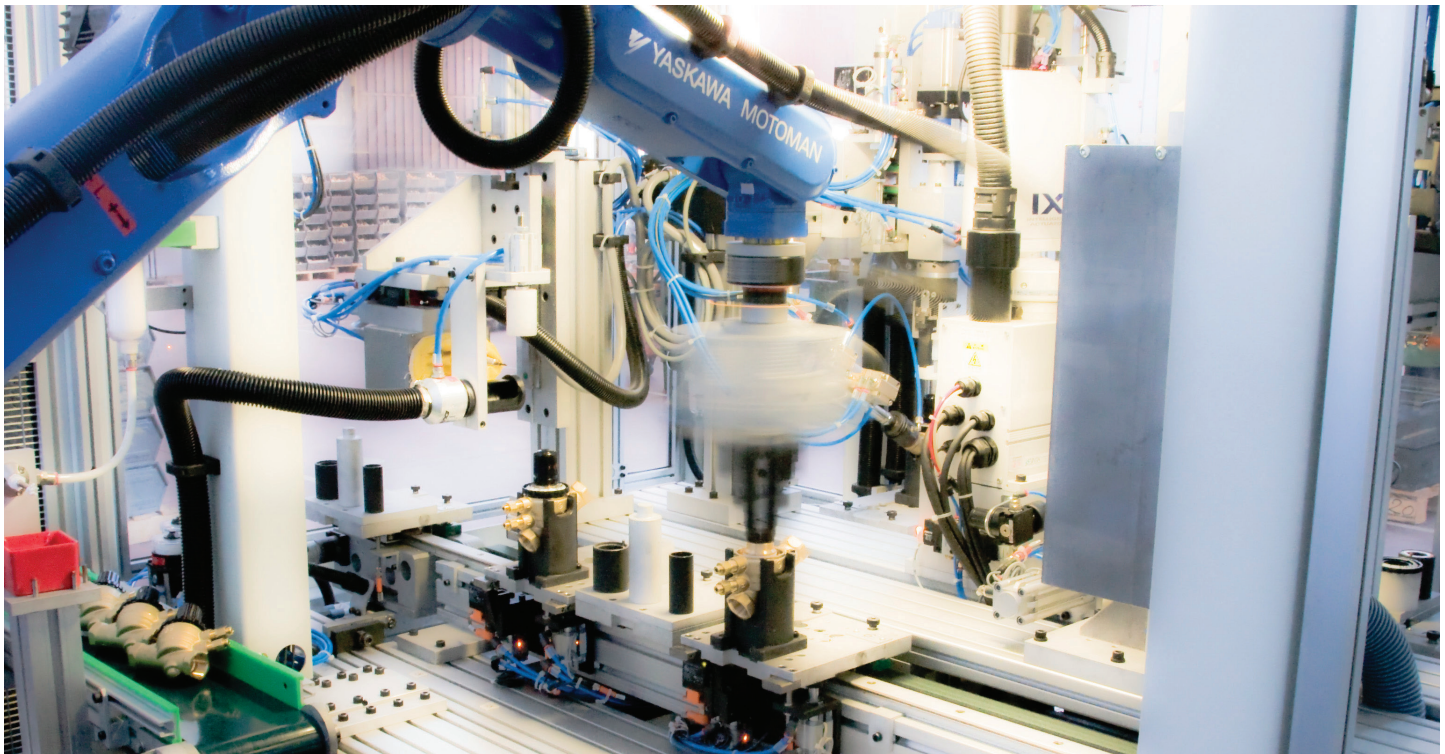

Fully automatic assembling machine. Extreme precision and high reliability eliminate human error. Every valve goes through three different pressure tests and is then marked with a unique product code.

HCI reserves the right to change the described products and the relative technical data at any time and without prior notice. HCI makes every attempt to ensure all information within this document is accurate. However, the company does not accept any liability for incorrect information published within this document. Please contact us at csr@hciterminator.com for questions or more information.

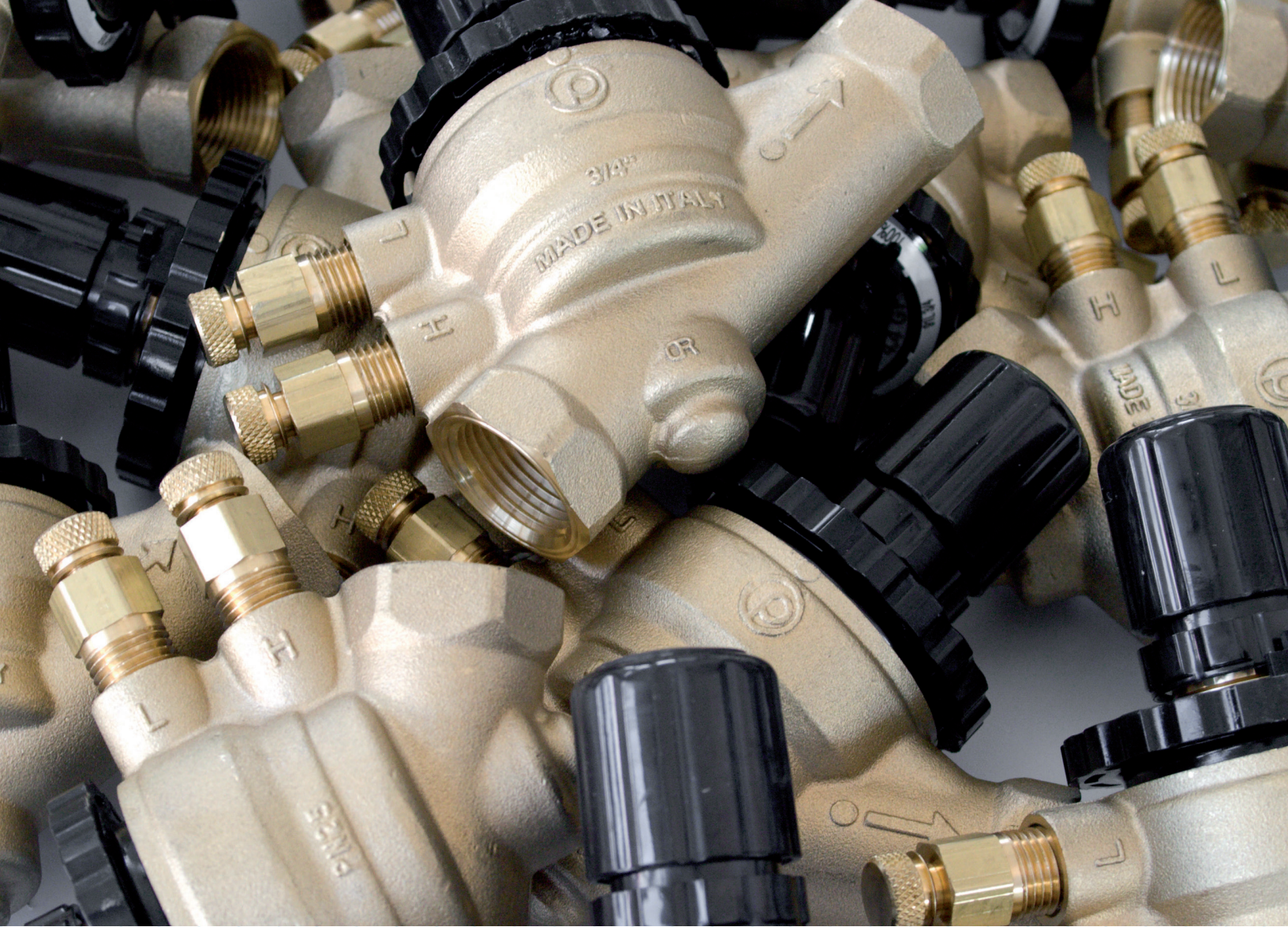

7243 Miller Drive, Warren, MI 48092
www.jomarhydraulics.com
phone: (586) 268-1220
fax: (586) 979-8315

LIT-JH-PSB

Jomar Hydraulics • 7243 Miller Drive, Warren, MI 48092 • www.jomarhydraulics.com • phone: (586) 268-1220 • fax: (586) 979-8315