



Installation Operation & Maintenance Instructions

IMPORTANT

Please read the installation operation and maintenance instruction prior to using any of our components.
Failure to follow the instructions may damage the component and/or void the warranty.

Contents

General Information	3
Water Treatment	3
Connection Guidelines	3
Threaded Connections.....	3
Factory Assembled Threaded Connections.....	4
Solder Connections.....	4
Press Connections.....	4
Union Connection.....	4
Flange, Groove and Weld Connections.....	5
Flanged Ends.....	5
Grooved Ends.....	5
Weld Ends.....	5
Flexible Hose Union Connection.....	5
Manual Balancing Valves	5
Terminator B (1/2" – 2").....	5
Terminator B (2 1/2" – 12").....	7
Terminator G (1/2" – 2").....	7
Terminator G (2 1/2" – 12").....	8
Metering Station	9
Terminator MS (1/2" – 3/4").....	9
Terminator MS (2 1/2" – 12").....	9
Automatic Balancing Valve	10
Terminator A (1/2" – 2").....	10
Terminator A (2 1/2" – 12").....	11
Pressure Independent Control Valve	11
TPICV 91 Series (1/2" – 3/4").....	11
TPICV 93 Series (3/4" – 1-1/4").....	12
TPICV 85 Series (1-1/2" – 2").....	13
TPICV 94F Series (2" – 6").....	13
Combination Strainer Valves	14
Terminator S (1/2" – 2").....	14
Terminator S (2 1/2" – 12").....	15
Terminator Y (1/2" – 2").....	16
Terminator Y (2 1/2" – 12").....	16
Combination Ball Valve	17
Terminator N (1/2" – 2").....	17
Union	17
Terminator U (1/2" – 2").....	17
Butterfly Valve	17
Flexible Hoses	18
Warranty	20
Replacement Guides	21
EPDM Flat Washer for Union Seal on Terminator A, S & Y.....	21
Viton O-rings for Union Seal on Terminator and Terminator B.....	22

General Information

The installation and operation information which follows represents the basics for successful use of valves furnished by **Jomar Hydronics**

Additional information such as product specifications, coil piping package details, hose kit details and warranty information can be found at www.jomarhydronics.com. If there are any questions or concerns which are not addressed on the website, or in the following, please contact us at **(586) 268-1220 or csr@jomar.com**

For proper operation, make sure that the system in which the valve is installed is free of debris, and that the water is devoid of entrained air. Air and debris will cause the balancing valves supplied by **Jomar Hydronics** to function improperly. A strainer with a minimum 20 mesh screen is recommended upstream of all balancing valves to prevent clogging. High point and inline air vents are also recommended to ensure all entrained air is removed.

On chilled water systems, the test ports may seep after a reading is taken. Re-install the port cap and wait approximately one minute. Check the port. If seepage is still present, re-insert probe and remove slowly to allow port to seal.

Performance Guarantee:

Jomar Hydronics guarantees to the original purchaser that the equipment of its manufacture will perform at the rated capacity as stated only when (1) properly installed, connected, started, operated and maintained in accordance with Company instruction(s) and/or information guide(s), as revised from time to time, (2) used for the applications specified and (3) used in the environments as specified or as limited. If equipment is part of a greater system, the Company accepts responsibility only for the equipment manufactured by it.

Water Treatment

Introduction of chemical cleaners, stabilizers and solvents into the systems may cause damage to the seats, seals, liners and gaskets or cause stress corrosion cracks in the product. Consult a water treatment specialist whenever introducing chemicals. It is important that you analyze all aspects of your systems components and the systems application with any introductions of chemicals into a system. It is solely the responsibility of the purchaser, contractor or engineer to review the material specification sheets for compatibility of these products. The documentation for the products described herein are subject to change at any time without notice. To obtain a copy of the current product specification sheets, **please visit www.jomarhydronics.com or contact us at (586) 268-1220 or csr@jomar.com**.

Connection Guidelines

Threaded Connections

Teflon tape or pipe-joint compound (pipe dope) must be used when installing NPT threaded connections, however both tape and dope must not be used on the same connection. The use of Teflon tape in addition to a pipe dope compound can be dangerous. It can result in too much material between the flanks of the threads. Additionally, using both tape and dope can cause over tightening due to the lubricating effect of both materials.

Teflon Tape

Before installation, all mating pipe threads should be checked to ensure that there is no damage to the threads. Also make sure that all threads are clean from debris. PTFE tape should always be wrapped in the direction of the threads. Tape should be stretched tight around the threads to be ensured that it is securely attached. Each successive layer should overlap the previous layer by 1/2 to 2/3 and continue wrapping until the entire threaded portion of the pipe is covered. (minimum of 3 full turns). An excess amount of tape can prevent mating threads from fully engaging, therefore reducing the shear point of the threads. Be sure not to over torque the threaded valves during installation. Doing so could cause damage to be done to the valves or pipe-line.

Pipe Dope

Be sure that the sealant is proper for the specific application in question and that all applicable codes are followed.

Factory Assembled Threaded Connections

All threaded bosses found on our components will contain either a PT port, accessory, accessory extension, or plug. All of the connections are made using Teflon tape or Loctite, and are factory tested up to 120 PSI to ensure a leak free joint. The removal or modification of any of these connections voids the warranty of the joint, as well as the warranty of the component. Contact us prior to modifying any factory assembled connections.

Solder Connections

These valves are designed for soft soldering. Using standard soldering procedure, prepare the copper pipe and valve's fitting cup. When soldering union end tailpieces, remove the O-ring or washer to prevent damage of the seal. When soldering, a heat sink must be used. Before applying heat, wrap a wet rag around the valve body. Solder the valve with the ball in the closed position. Never solder the downstream end of the valve while there is upstream pressure/or fluid trapped in the cavity around or in the ball. When applying heat, direct the flame away from the valve body at the solder end connection of the valve. Allow valve to cool before operating the ball.

Press Connections

The Jomar press system can be used with "K", "L" & "M" grades of ridged copper tubing. Cut the copper pipe to the appropriate length. Be sure that the end is cut square. The pipe may have to be sanded to remove any buildup. Make sure the inside and outside of the pipe is free from all debris, and deburr both sides before installing valve.

A minimum of 2 pipe diameters spacing is recommended between any two press joints. A minimum distance of 5 pipe diameters is required between any solder connections and a Jomar press joint. Extreme care should be taken to ensure that any heat applied to nearby fittings does not reach the Jomar press joint. If possible, perform all solder connections before installing Jomar press valves and allow the pipe to cool before installing a press connection.

When installing the valve, use a twisting motion to slide the valve onto the pipe body. Make sure that the O-ring for the press valve is seated correctly around the pipe. Once on the pipe, mark the insertion depth to ensure that the joint does not move prior to the crimping process. Valves have internal stops to limit the insertion depth, do not force the pipe past these stops.

Using the proper crimping tool, follow the tool manufacturer's instructions for use. Be sure that the tool is in working condition before attempting to crimp the valve to the pipe body. Not doing so may result in damage to the valve.

Union Connection

The components listed below, in sizes 1/2" – 2", have a union connection. All of these connections use an o-ring or rubber washer to ensure the seal. Be sure the o-ring or washer is present before tightening the connection.

Terminator A – Automatic Balancing Valve

Terminator B – Manual Balancing Valve

Terminator N – Combination Ball Valve

Terminator U - Union

Terminator S – Combination strainer valve

Terminator Y – Combination strainer valve

To ensure the connection, secure the union nut hand tight. Then tighten an additional 1/4 turn. The following nominal torques are for reference;

1/2" & 3/4" Sizes 45.0 – 62.0 ft-lbs

1" Sizes 59.0 – 73.7 ft-lbs

1-1/4" Sizes 81.1 – 95.9 ft-lbs

1-1/2" Size 110.6 – 125.2 ft-lbs

2" Size 148 – 164.1 ft-lbs

Flange, Groove and Weld Connections

Flanged Ends

When installing flanged joints, ensure that the flanges are properly aligned prior to installation. Be sure to evaluate that no side loading is occurring. When tightening flanges, do so in a star type pattern to properly level out the joint. All bolting materials and torques must meet applicable codes. Appropriate gasketing material must be used when installing flange-mounted valves

Grooved Ends

1. Apply a thin layer of grease or graphite paste to the pipe end, valve end, and rubber gasket.
2. Slip the rubber gasket completely over the pipe. Taking care to keep the gasket lip from overhanging the pipe end
3. Align the valve with the pipe end. Slide the gasket until it is centered between both grooves. Apply grease on the outside of the gasket.
4. Put housing clamps over gasket. Insert bolts and nuts.
5. Alternate tightening the nuts so that the housing clamps come together evenly. Once the housing halves make metal to metal contact, no additional tightening is necessary or desirable. Uneven tightening can result in the gasket pinching.

In addition to the instruction above, adhere to any specific recommendations / instructions provided by the coupling manufacturer.

Weld Ends

1. Clean the end of the valve and pipe where the weld will be made. Align the connections together.
2. Tack weld the valve to the pipe and observe fit.
3. Prior to completing the weld, examine the piping upstream/downstream. Ensure that all flange gaskets and butterfly valves in close proximity to the weld have been removed. The heat from the weld will damage these components if they are left in place.
4. Finish welding the valve to the pipe. Allow the connection to cool completely.
5. Re-install flange gaskets and butterfly valves if necessary.

Flexible Hose Union Connection

See flexible hose section

Manual Balancing Valves

Terminator B (1/2" – 2")

IMPORTANT

Please read the Connection Guidelines prior to installing these components. Failure to follow these instructions may damage the component and/or void the warranty.

Installation:

1. The Terminator B is a unidirectional balancing device. The arrow on the valve body must be in the direction of flow.
2. For horizontal installations, the valve should be installed with the readout port on or above the horizontal center line. DO NOT install valve with the readout port facing down. Debris from the line can clog the port during the readout process. This can result in leaks.
3. There are no minimum upstream or downstream straight-piping requirements for the Terminator B.

To Balance:

1. Take a reading using a differential pressure gauge calibrated in inches of water. Connect the "high" side line to the port marked "H" (closest to the union), and the "low" side line to the port marked "L" (closest to the handle).
2. The desired differential pressure can be found by referencing the location tag attached to the valve or by referring to the Terminator B pressure drop chart which is part of the spec sheet.
3. Throttle the valve until the desired differential pressure is indicated on the gauge. Loosen the memory stop on the valve handle, and rotate the stop counterclockwise until it touches the valves travel stop. Tighten the memory stop.
4. Record the indicator pad setting on balancing location tag attached to the valve. This will allow the valve to be properly reset in the event the memory stop setting is lost.

To Vent Air:

1. Make sure an optional air vent is installed in the accessory boss.
2. Close the valve between 45° -60° . Open vent to purge air from coil.

To Replace Venturi:

1. Remove union nut, tailpiece and, o-ring from valve body
2. Using small needle nose pliers, a flat head screwdriver, or a rat tail file, depending on venturi model. Rotate the venturi counter-clockwise until the venturi threads disengage from the valve body.

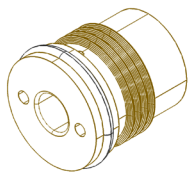

Needle nose pliers

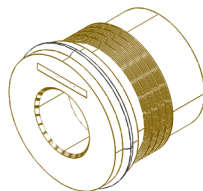

Flat head screwdriver

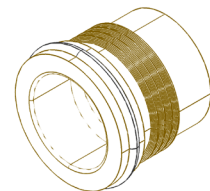

Rat tail file

3. Slide venturi insert out of the valve body.
4. Slide new venturi insert into the valve body until resistance is felt. Using the appropriate tool, rotate venturi 1 ½ turns counter-clockwise to ensure alignment.
5. Rotate venturi clockwise until the insert is snug. 4-7 full rotations, depending on venturi model.
6. To verify venturi is properly installed, sight down the interior of the valve. The high side PT port hole should be fully visible and unobstructed.
7. Reassemble o-ring, tailpiece and union nut onto valve body.

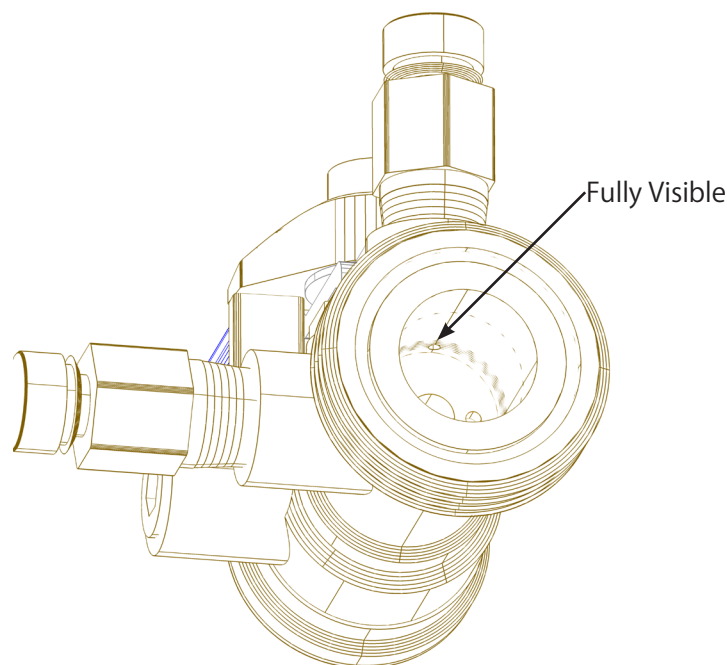

Terminator B (2 1/2" – 12")

IMPORTANT

Please read the Connection Guidelines prior to installing these components. Failure to follow these instructions may damage the component and/or void the warranty.

Installation:

1. The Terminator B is a unidirectional balancing device. The arrow on the valve body must be in the direction of flow.
2. For horizontal installations, the valve should be installed with the readout port on or above the horizontal centerline. DO NOT install valve with the readout port facing down. Debris from the line can clog the port during the readout process. This can result in leaks.
3. 5 straight pipe diameters are required upstream, and 2 1/2 straight pipe diameters are required downstream of the Terminator B to ensure specified accuracy.

To Balance:

1. Take a reading using a differential pressure gauge calibrated in inches of water. Connect the "high" side line to the upstream port, and the "low" side line to the downstream port.
2. The desired differential pressure can be found by referencing the location tag attached to the valve or by referring to the Terminator B pressure drop chart which is part of the spec sheet.
3. Using the butterfly valve, throttle the valve until the desired differential pressure is indicated on the gauge.

Terminator G (1/2" – 2")

IMPORTANT

Please read the Connection Guidelines prior to installing these components. Failure to follow these instructions may damage the component and/or void the warranty.

Installation:

- 1.1. The Terminator G is a unidirectional balancing device. The arrow on the valve body must be in the direction of flow.
- 2.2. The Terminator G should be installed so that the Microset hand wheel readout is readily visible for the balancing/commissioning agent.
- 3.3. 5 straight pipe diameters are required upstream, and 2 straight pipe diameters are required downstream of the Terminator G to ensure specified accuracy.

To Balance:

1. Take a reading using a differential pressure gauge calibrated in inches of water. Connect the "high" side line to

the upstream port (red cap retainer), and the “low” side line to the downstream port (blue cap retainer).

2. The desired differential pressure can be found by referencing the location tag attached to the valve or by referring to the Terminator G pressure drop chart which is part of the spec sheet.
3. Throttle the valve until the desired differential pressure is indicated on the gauge. Remove the top cover of the hand wheel to expose the memory stop screw. Tighten the screw using a 3mm hex wrench until snug. Reassemble the top cover.
4. Record the hand wheel setting on balancing location tag attached to the valve. This will allow the valve to be properly reset in the event the memory stop setting is lost.

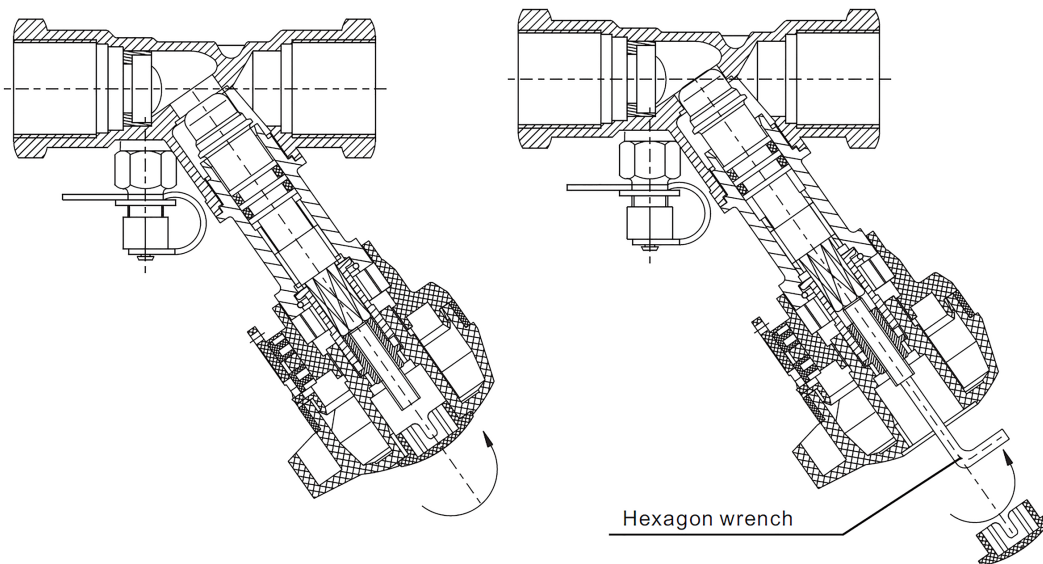

Terminator G (2 1/2" – 12")

IMPORTANT

Please read the Connection Guidelines prior to installing these components. Failure to follow these instructions may damage the component and/or void the warranty.

CAUTION

This valve must not be lifted by holding the hand wheel.

Installation:

1. The Terminator G is a unidirectional balancing device. The arrow on the valve body must be in the direction of flow.
2. For horizontal installations, the valve should be installed with the readout port on or above the horizontal centerline. DO NOT install valve with the readout port facing down. Debris from the line can clog the port during the readout process. This can result in leaks.
3. 5 straight pipe diameters are required upstream, and 2 1/2 straight pipe diameters are required downstream of the Terminator G to ensure specified accuracy. If the Terminator G is located on the outlet of a pump. There must be a minimum of 10 pipe diameter between the pump outlet and the valve inlet.

To Balance:

1. Take a reading using a differential pressure gauge calibrated in inches of water. Connect the "high" side line to the upstream port, and the "low" side line to the downstream port.
2. The desired differential pressure can be found by referencing the location tag attached to the valve or by referring to the Terminator G pressure drop chart which is part of the spec sheet.
3. Throttle the valve until the desired differential pressure is indicated on the gauge. Using a hex wrench, loosening the set screws on the limitation cap. Slide the cap up until it sits snug against the plastic indicator. Tighten the set screws.
4. Record the hand wheel setting on balancing location tag attached to the valve. This will allow the valve to be properly reset in the event the memory stop setting is lost.

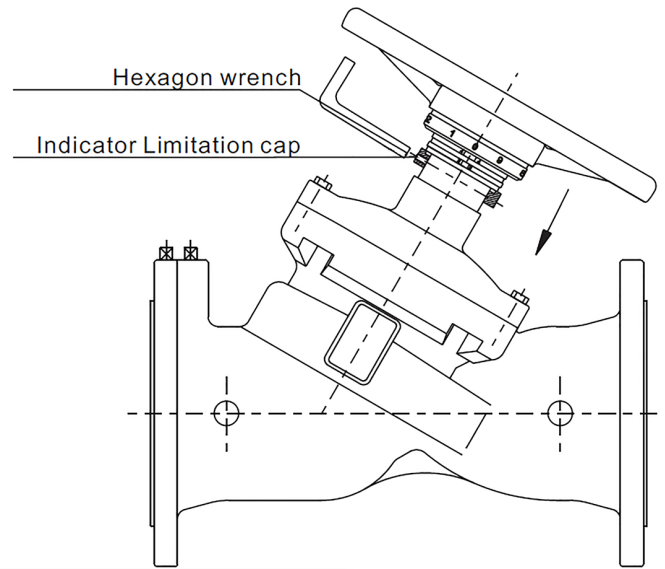
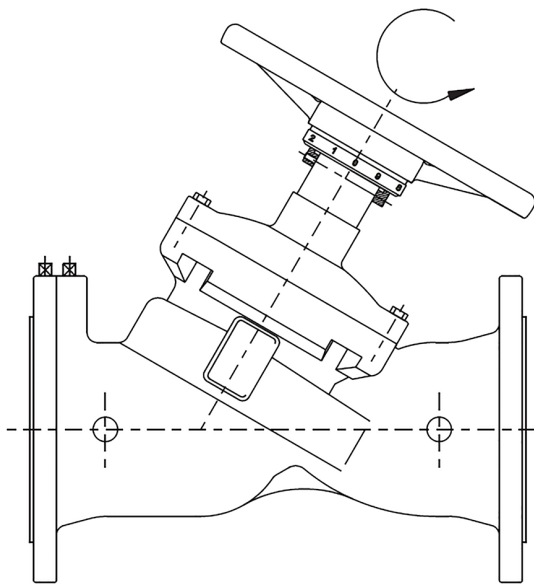

Metering Station

Terminator MS (1/2" – 3/4")

IMPORTANT

Please read the Connection Guidelines prior to installing these components. Failure to follow these instructions may damage the component and/or void the warranty.

Installation:

1. The Terminator MS is a unidirectional flow verification device. The arrow on the valve body must be in the direction of flow.
2. For horizontal installations, the valve should be installed with the readout port on or above the horizontal centerline. DO NOT install valve with the readout port facing down. Debris from the line can clog the port during the readout process. This can result in leaks.
3. There are no minimum upstream or downstream straight-piping requirements for the Terminator MS.

Flow Verification:

1. Take a reading using a differential pressure gauge calibrated in inches of water. Connect the "high" side line to the port marked "H", and the "low" side line to the port marked "L".
2. The desired differential pressure can be found by referencing the location tag attached to the valve or by referring to the Terminator B pressure drop chart which is part of the spec sheet.

To Replace Venturi:

1. See "To Replace Venturi" sub section under Manual Balancing Valve – Terminator B (1/2" – 2")

Terminator MS (2 1/2" – 12")

IMPORTANT

Please read the Connection Guidelines prior to installing these components. Failure to follow these instructions may damage the component and/or void the warranty.

Installation:

1. The Terminator MS is a unidirectional flow verification device. The arrow on the valve body must be in the direction of flow.
2. The valve should be installed with the readout port on or above the horizontal centerline. DO NOT install valve with the readout port facing down. Debris from the line can clog the port during the readout process. This can result in leaks.
3. 5 straight pipe diameters are required upstream, and 2 1/2 straight pipe diameters are required downstream of the Terminator MS to ensure specified accuracy.

Flow Verification:

1. Take a reading using a differential pressure gauge calibrated in inches of water. Connect the "high" side line to the upstream port, and the "low" side line to the downstream port.
2. The desired differential pressure can be found by referencing the location tag attached to the valve or by referring to the Terminator B pressure drop chart which is part of the spec sheet.

Automatic Balancing Valve

Terminator A (1/2" – 2")

IMPORTANT

Please read the Connection Guidelines prior to installing these components. Failure to follow these instructions may damage the component and/or void the warranty.

Installation:

1. The Terminator A is a unidirectional flow limiting device. The arrow on the handle must be in the direction of flow.
2. For horizontal installations, the valve should be installed with the readout port on or above the horizontal centerline. DO NOT install valve with the readout port facing down. Debris from the line can clog the port during the readout process. This can result in leaks.
3. There are no minimum upstream or downstream straight-piping requirements for the Terminator A.

Verification of Operation:

1. The Terminator A contains a spring loaded cartridge individually calibrated for specified flow rates. The cartridge maintains the flow rate within the differential pressure range of 2-50 PSI.
2. Verification that the cartridge is engaged and maintaining the designed flow rate can be achieved by measuring the differential pressure across the valve using the PT ports. If the differential pressure is between 2-50 PSI, the flow limiter is operating correctly.
3. The PT ports are for verification only; not for flow measurement or GPM adjusting. To achieve a different flow rate, a new cartridge will need to be installed.
4. The Terminator A cartridges are field changeable. Removal of these cartridges requires no special tools.
5. Dirt, debris, or entrapped air can cause improper reading.

Cartridge Replacement:

1. Shut off supply and return side isolation valves.

2. Drain coil.
3. Remove the service cap and pull cartridge out.
4. Reuse cartridge gasket on the replacement cartridge. Insert replacement cartridge into valve body.
5. Replace and tighten end cap.
6. Slowly return isolation valve to the open position.
7. Vent air.

Terminator A (2 1/2" – 12")

IMPORTANT

Please read the Connection Guidelines prior to installing these components. Failure to follow these instructions may damage the component and/or void the warranty.

Installation:

1. The Terminator A is a unidirectional flow limiting device. The arrow on the body must be in the direction of flow.
2. For horizontal installations, the valve should be installed with the readout port on or above the horizontal centerline. DO NOT install valve with the readout port facing down. Debris from the line can clog the port during the readout process. This can result in leaks.
3. There are no minimum upstream or downstream straight-piping requirements for the Terminator A.

Verification of Operation:

1. The Terminator A contains spring loaded cartridges individually calibrated for specified flow rates. The cartridges maintain the flow rate within the differential pressure range of 2-50 PSI.
2. Verification that the cartridges are engaged and maintaining the designed flow rate can be achieved by measuring the differential pressure across the valve using the PT ports. If the differential pressure is between 2-50 PSI, the flow limiter is operating correctly.
3. The PT ports are for verification only; not for flow measurement or GPM adjusting. To achieve a different flow rate, a new cartridge will need to be installed.
4. Dirt, debris, or entrapped air can cause improper reading.

Pressure Independent Control Valve

TPICV 91 Series (1/2" – 3/4")

IMPORTANT

Please read the Connection Guidelines prior to installing these components. Failure to follow these instructions may damage the component and/or void the warranty.

Installation:

1. The 91 Series is a unidirectional balancing device. The arrow on the body must be in the direction of flow.
2. For horizontal installations, the valve should be installed with the readout port and actuator on or above the horizontal centerline.
 - a. DO NOT install valve with the readout port facing down. Debris from the line can clog the port during the readout process. This can result in leaks.
 - b. DO NOT install valve with the actuator facing down. Condensation or fluid can drip and damage the actuator.
3. There are no minimum upstream or downstream straight-piping requirements for the 91 Series.

Flushing:

1. 91 Series can not be forward or back flushed through.

2. A main flush should be performed by bypassing the coil. Either a fixed flushing bypass such as the Terminator FB, or temporary flushing bypass, should be used.
3. The coil should be flushed prior to operation; this requires an additional drain located close to the PICV.
 - a. If the PICV is located on the supply side, the drain should be located directly downstream, prior to the coil. This allows the coil to be backflushed without introducing debris into the PICV.
 - b. If the PICV is located on the return side, the drain should be located directly upstream, between the coil and PICV. This allows the coil to be flushed without introducing debris into the PICV.

Verification of Operation:

1. The 91 Series contains a pressure regulated diaphragm. The diaphragm maintains the flow rate within the differential pressure range of 5-58 PSI.
2. Verification that the diaphragm is engaged and maintaining the designed flow rate can be achieved by measuring the differential pressure across the valve using the PT ports. If the differential pressure is between 5-58 PSI, the flow limiter is operating correctly.
3. The PT ports are for verification only; not for flow measurement.
4. Dirt, debris, or entrapped air can cause improper reading.
5. IMPORTANT: Water must contain less than 25 ppm of iron oxide to ensure proper operation of the 93 Series valve.

To Set Flow Rate:

1. The 91 Series max flow rate can be field set with the externally adjustable presetting ring.
2. Lift up on the lock pin
3. Rotate the ring to the required percentage identified on the location tag attached to the valve
4. Press the lock pin down

TPICV 93 Series (3/4" – 1-1/4")

IMPORTANT

Please read the Connection Guidelines prior to installing these components. Failure to follow these instructions may damage the component and/or void the warranty.

Installation:

1. The 93 Series is a unidirectional balancing device. The arrow on the body must be in the direction of flow.
2. For horizontal installations, the valve should be installed with the readout port and actuator on or above the horizontal centerline.
 - a. DO NOT install valve with the readout port facing down. Debris from the line can clog the port during the readout process. This can result in leaks.
 - b. DO NOT install valve with the actuator facing down. Condensation or fluid can drip and damage the actuator.
3. There are no minimum upstream or downstream straight-piping requirements for the 93 Series.

Flushing:

1. The regulating cartridge in the 93 series can be removed to allow for direct flushing
2. If the system is pressurized, isolate the coil from the rest of the system by closing the isolation on the supply and return side of the coil.
3. If the system is pressurized, open the low point drain and allow fluid to drain from isolated coil and relevant piping into a bucket or drain.
4. Using a 30mm socket, remove service cap.
5. Using a 32mm socket, remove regulating cartridge.
6. Replace service cap to allow for flushing.
7. After the flushing procedure is complete, reinstall regulation cartridge.

Verification of Operation:

1. The 93 Series contains a pressure regulated diaphragm. The diaphragm maintains

the flow rate within the differential pressure range of 5-58 PSI.

2. Verification that the diaphragm is engaged and maintaining the designed flow rate can be achieved by measuring the differential pressure across the valve using the PT ports. If the differential pressure is between 5-58 PSI, the flow limiter is operating correctly.
3. The PT ports are for verification only; not for flow measurement.
4. Dirt, debris, or entrapped air can cause improper reading.
5. IMPORTANT: Water must contain less than 25 ppm of iron oxide to ensure proper operation of the 93 Series valve.

To Set Flow Rate:

1. The 93 Series max flow rate can be field set with the externally adjustable presetting ring.
2. Lift up on the lock pin
3. Rotate the ring to the required percentage identified on the location tag attached to the valve
4. Press the lock pin down

TPICV 85 Series (1-1/2" – 2")

IMPORTANT

Please read the Connection Guidelines prior to installing these components. Failure to follow these instructions may damage the component and/or void the warranty.

Installation:

1. The 85 Series is a unidirectional balancing device. The arrow on the body must be in the direction of flow.
2. For horizontal installations, the valve should be installed with the readout port and actuator on or above the horizontal centerline.
 - a. DO NOT install valve with the readout port facing down. Debris from the line can clog the port during the readout process. This can result in leaks.
 - b. DO NOT install valve with the actuator facing down. Condensation or fluid can drip and damage the actuator.
3. There are no minimum upstream or downstream straight-piping requirements for the 85 Series.

Flushing:

1. The 85 Series has a multi directional ball that allows for flushing through the valve.
2. Remove actuator if one is already installed.
3. Rotate the ball until the arrow on the stem is point upstream.
4. The coil can now be flushed.
5. Rotate the ball until the arrow on the stem points downstream.
6. Re-mount actuator.

Verification of Operation:

1. The 85 Series contains a pressure regulated diaphragm. The diaphragm maintains the flow rate within the differential pressure range of 5-58 PSI.
2. Verification that the diaphragm is engaged and maintaining the designed flow rate can be achieved by measuring the differential pressure across the valve using the PT ports. If the differential pressure is between 5-58 PSI, the flow limiter is operating correctly.
3. The PT ports are for verification only; not for flow measurement.
4. Dirt, debris, or entrapped air can cause improper reading.
5. IMPORTANT: Water must contain less than 25 ppm of iron oxide to ensure proper operation of the 85 Series valve.

TPICV 94F Series (2" – 6")

IMPORTANT

Please read the Connection Guidelines prior to installing these components. Failure to follow these instructions may damage the component and/or void the warranty.

Installation:

1. The 94F Series is a unidirectional balancing device. The arrow on the body must be in the direction of flow.
2. For horizontal installations, the valve should be installed with the readout port and actuator on or above the horizontal centerline.
 - a. DO NOT install valve with the readout port facing down. Debris from the line can clog the port during the readout process. This can result in leaks.
 - b. DO NOT install valve with the actuator facing down. Condensation or fluid can drip and damage the actuator.
3. There are no minimum upstream or downstream straight-piping requirements for the 94F Series.

Flushing:

1. The 94F Series can be flushed through.

Verification of Operation:

1. The 94F Series contains a pressure regulated diaphragm. The diaphragm maintains the flow rate within the differential pressure range of 5-58 PSI.
2. Verification that the diaphragm is engaged and maintaining the designed flow rate can be achieved by measuring the differential pressure across the valve using the PT ports. If the differential pressure is between 5-58 PSI, the flow limiter is operating correctly.
3. The PT ports are for verification only; not for flow measurement.
4. Dirt, debris, or entrapped air can cause improper reading.
5. IMPORTANT: Water must contain less than 25 ppm of iron oxide to ensure proper operation of the 94F Series valve.

Combination Strainer Valves

Terminator S (1/2" – 2")

IMPORTANT

Please read the Connection Guidelines prior to installing these components. Failure to follow these instructions may damage the component and/or void the warranty.

Installation:

1. The Terminator S is a unidirectional Straining device. The arrow on the body must be in the direction of flow.
2. For horizontal installations, the valve should be installed with the readout port on or above the horizontal centerline. DO NOT install valve with the readout port facing down. Debris from the line can clog the port during the readout process. This can result in leaks.

Strainer Service: (Strainer service requires snap ring pliers.)

1. A regular cleaning schedule should be maintained so that the screens do not become clogged.
2. Isolate strainer basket by turning valve handle to the closed position. CAUTION: VALVE MUST BE FULLY CLOSED PRIOR TO REMOVAL OF ACCESS CAP. FAILURE TO FULLY CLOSE VALVE MAY RESULT IN PERSONAL INJURY.
3. Relieve pressure from side access cap by opening cap slowly or by removing plug in cap.
4. Remove snap ring using snap ring pliers.
5. Remove strainer basket. Clean or replace.
6. Re-install strainer basket, snap ring, cap and cap plug.
7. Open valve to return terminal unit into service.

Backflushing the Strainer:

1. A regular cleaning schedule should be maintained so that the screens do not become clogged.
2. Backflushing the Terminator S requires the use of an optional blowdown valve installed in the access cap.
3. Isolate strainer basket by turning valve handle to the closed position. CAUTION: OPTIONAL BLOWDOWN VALVE MUST BE FULLY CLOSED PRIOR TO CLOSING THE TERMINATOR S VALVE. FAILURE TO FULLY CLOSE BLOWDOWN VALVE MAY RESULT IN PERSONAL INJURY.
4. Remove backflush cap located upstream of the Terminator S valve stem.
5. Using an allen wrench, slowly back out the backflush plug to open internal backflush port.
6. Open optional blowdown valve, taking preparation for water to flow into a bucket or drain.
7. Allow valve to backflush for at least 4 seconds.
8. Close blowdown valve.
9. Using an allen wrench, tighten the backflush plug until it is seated snugly in its original position.
10. Replace backflush cap.
11. Open Terminator S valve to return terminal unit into service.

Terminator S (2 1/2" – 12")

IMPORTANT

Please read the Connection Guidelines prior to installing these components. Failure to follow these instructions may damage the component and/or void the warranty.

Installation:

1. The Terminator S is a unidirectional Straining device. The arrow on the body must be in the direction of flow.
2. For horizontal installations, the valve should be installed with the readout port on or above the horizontal centerline. DO NOT install valve with the readout port facing down. Debris from the line can clog the port during the readout process. This can result in leaks.

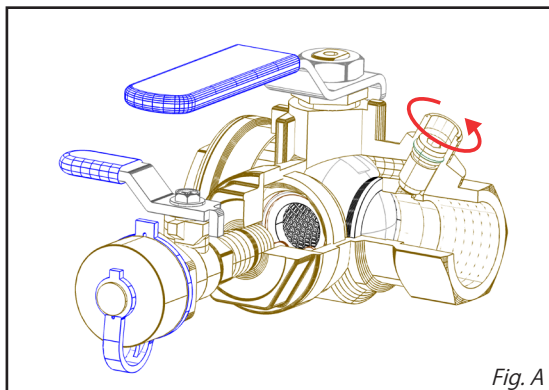

Fig. A

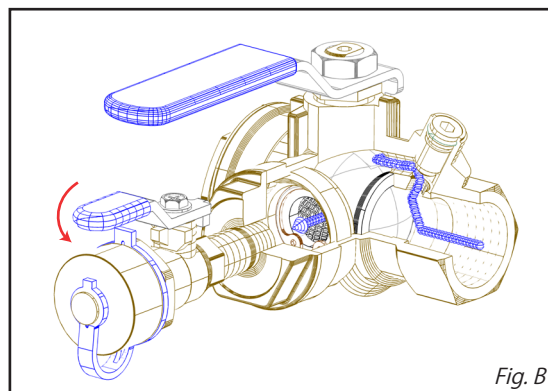

Fig. B

Strainer Service:

1. A regular cleaning schedule should be maintained so that the screens do not become clogged.
2. Isolate the coil from the rest of the system by closing the butterfly valve integrated in the Terminator S and by closing the isolation valve located on the return side of the coil.
3. Open the low point drain and allow fluid to drain from isolated coil and relevant piping into a bucket or drain. Note: This drain may be located on the Terminator S itself.
4. Remove service cap.
5. Remove strainer screen.
6. Cleaning care should be taken in cleaning screens. After removing, the screen should be soaked in a cleaning solution or cleaned by using a brush. Do not allow trapped material to harden in the screen.
7. Reinstall strainer screen, replace service cap, open isolation valves, and vent air.

Strainer Flushing:

1. A regular cleaning schedule should be maintained so that the screens do not become clogged.

2. Flushing the Terminator S requires the use of an optional blowdown valve installed in the access cap.
3. Open optional blowdown valve, taking preparation for water to flow into a bucket or drain.
4. Allow valve to flush for at least 4 seconds.
5. Close blowdown valve.

Terminator Y (1/2" – 2")

IMPORTANT

Please read the Connection Guidelines prior to installing these components. Failure to follow these instructions may damage the component and/or void the warranty.

Installation:

1. The Terminator Y is a unidirectional Straining device. The arrow on the handle must be in the direction of flow.
2. For horizontal installations, the valve should be installed with the readout port on or above the horizontal centerline. DO NOT install valve with the readout port facing down. Debris from the line can clog the port during the readout process. This can result in leaks.

Strainer Service:

1. A regular cleaning schedule should be maintained so that the screens do not become clogged.
2. Isolate the coil from the rest of the system by closing the ball valve integrated in the Terminator Y and by closing the isolation valve located on the return side of the coil.
3. Open the low point drain and allow fluid to drain from isolated coil and relevant piping into a bucket or drain. Note: This drain may be located on the Terminator Y itself.
4. Remove service cap.
5. Remove strainer screen.
6. Cleaning care should be taken in cleaning screens. After removing, the screen should be soaked in a cleaning solution or cleaned by using a brush. Do not allow trapped material to harden in the screen.
7. Reinstall strainer screen, replace service cap, open isolation valves, and vent air.

Strainer Flushing:

1. A regular cleaning schedule should be maintained so that the screens do not become clogged.
2. Flushing the Terminator Y requires the use of an optional blowdown valve installed in the access cap.
3. Open optional blowdown valve, taking preparation for water to flow into a bucket or drain.
4. Allow valve to flush for at least 4 seconds.
5. Close blowdown valve.

Terminator Y (2 1/2" – 12")

IMPORTANT

Please read the Connection Guidelines prior to installing these components. Failure to follow these instructions may damage the component and/or void the warranty.

Installation:

1. The Terminator S is a unidirectional Straining device. The arrow on the body must be in the direction of flow.
2. For horizontal installations, the valve should be installed with the readout port on or above the horizontal centerline. DO NOT install valve with the readout port facing down. Debris from the line can clog the port during the readout process. This can result in leaks.

Strainer Service:

1. A regular cleaning schedule should be maintained so that the screens do not become clogged.

2. Isolate the coil from the rest of the system by closing the isolation valve upstream of the Terminator Y and by closing the isolation valve located on the return side of the coil.
3. Open the low point drain and allow fluid to drain from isolated coil and relevant piping into a bucket or drain. Note: This drain may be located on the Terminator Y itself.
4. Remove service cap.
5. Remove strainer screen.
6. Cleaning care should be taken in cleaning screens. After removing, the screen should be soaked in a cleaning solution or cleaned by using a brush. Do not allow trapped material to harden in the screen.
7. Reinstall strainer screen, replace service cap, open isolation valves, and vent air.

Strainer Flushing:

1. A regular cleaning schedule should be maintained so that the screens do not become clogged.
2. Flushing the Terminator S requires the use of an optional blowdown valve installed in the access cap.
3. Open optional blowdown valve, taking preparation for water to flow into a bucket or drain.
4. Allow valve to flush for at least 4 seconds.
5. Close blowdown valve.

Combination Ball Valve

Terminator N (1/2" – 2")

IMPORTANT

Please read the Connection Guidelines prior to installing these components. Failure to follow these instructions may damage the component and/or void the warranty.

Installation:

1. For horizontal installations, the valve should be installed with the readout port on or above the horizontal centerline. DO NOT install valve with the readout port facing down. Debris from the line can clog the port during the readout process. This can result in leaks.
2. The Terminator N can be furnished with a second accessory, such as a drain or air vent. If such an accessory is included, orient the valve to allow for the proper operation of these accessories.

Union

Terminator U (1/2" – 2")

IMPORTANT

Please read the Connection Guidelines prior to installing these components. Failure to follow these instructions may damage the component and/or void the warranty.

Installation:

1. For Horizontal installations, the valve should be installed with the readout port on or above the horizontal centerline. DO NOT install valve with the readout port facing down. Debris from the line can clog the port during the readout process. This can result in leaks.
2. The Terminator U can be furnished with a second accessory, such as a drain or air vent. If such an accessory is included, orient the valve to allow for the proper operation of these accessories.

Butterfly Valve

IMPORTANT

Please read the Connection Guidelines prior to installing these components. Failure to follow these instructions may damage the component and/or void the warranty.

Installation:

1. Gaskets are not required as the seat face serves as the sealing surface.
2. Before installation, close the valve firmly. Slide the valve between the mating flanges and hand tighten the bolts to a point where the valve is held firmly in place.
3. Slowly rotate the handle to be sure that the disk swings freely.
4. Leave the valve in the open position and tighten the flange bolts.
5. After completion of tightening the bolts, once again rotate the handle to ensure full range operation.

Maintenance:

No standard lubrication or maintenance is required. However, periodic rotation of the valve throughout its full range is recommended.

Flexible Hoses

Installation:

1. Adhere to allowable bend radius. (see table below)
2. Verify that the installation conditions do not cause torsion of flexible hose. (See figure 1 below)
3. If necessary modify the installation in the event that it is not possible to adhere to the allowable bend radius (see paragraph 1 below). For example, add an intermediary right angle (see figure 2 below).
4. Do not submit the connectors to tension, either from the installation, or as a result of pressure or expansion (see figure 3 below).
5. The braiding of the flexible must never be in contact with cement, plaster, or any other materials/fluids capable of causing corrosion.

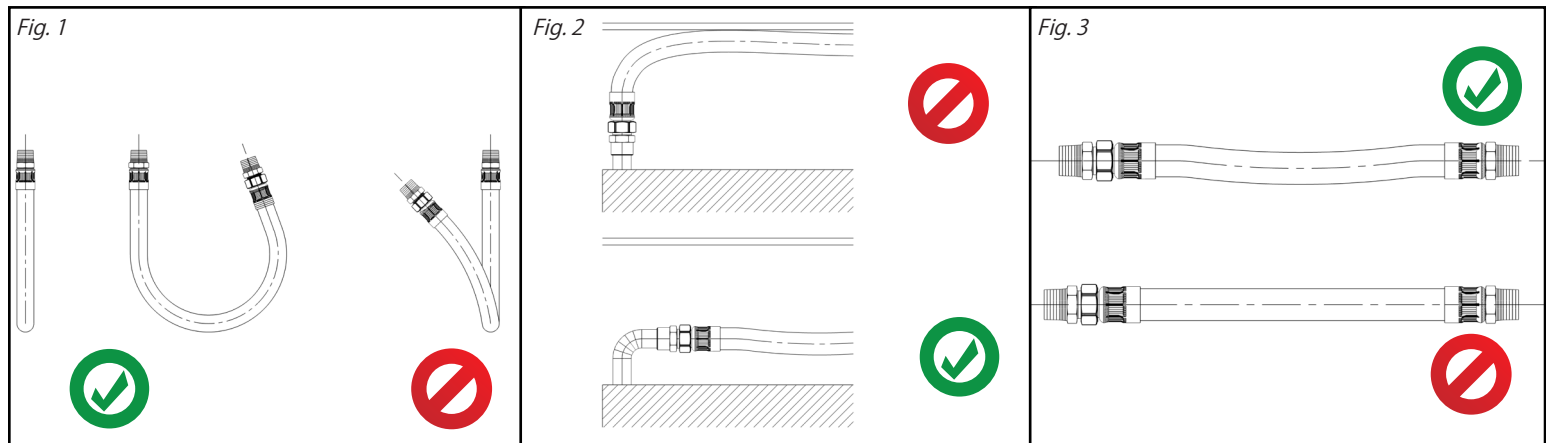

ON INSTALLATION:

Avoid tension due to stretching during the course of tightening the connectors. Do not turn fittings in the hose. Do not twist hose. Avoid sharp bends, kinking or twisting of the hose during installation. The 1/2", 3/4" and 1" hose connection is a metal to metal seal. The brass mating surfaces should be smooth and free of debris. The 1-1/4", 1-1/2" and 2" hose connection use a specially designed gasket. Do not install without the gasket. **Do not** use pipe dope or tape sealants on the adaptor when connecting to the swivel nut.

- A. Install and tighten the fixed male connector.
- B. Remove the swivel adaptor from the swivel nut. Install and tighten the swivel adaptor.
- C. Install and tighten the adaptor to the swivel nut. Use two spanners in order to screw the union together: One to hold the hexagon of the adaptor. The other to tighten the nut.

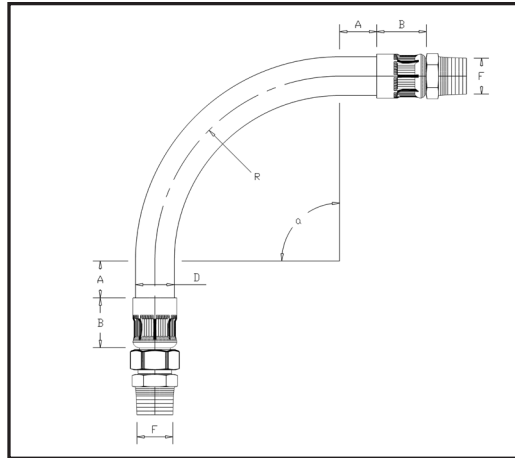

ID	F	Length	R _{min}	A _{min}	B	D	α _{max}
13	1/2" - 14 NPT	12"	60	40	23	17	89°
		18"	60	40	23	17	180°
		24"	60	40	23	17	180°
		36"	60	40	23	17	180°
19	3/4" - 14 NPT	12"	80	55	35	26	32°
		18"	80	55	35	26	126°
		24"	80	55	35	26	180°
		36"	80	55	35	26	180°
25	1 - 11,5 NPT	12"	110	65	35	35	5°
		18"	110	65	35	35	75°
		24"	110	65	35	35	142°
		36"	110	65	35	35	180°
32	1-1/4" - 11,5 NPT	18"	120	100	46	42	30°
		24"	120	100	46	42	92°
		36"	120	100	46	42	180°
40	1-1/2" - 11,5 NPT	18"	200	140	62	53	5°
		24"	200	140	62	53	27°
		36"	200	140	62	53	104°
50	2" - 11,5 NPT	24"	280	230	57	63	5°
		36"	280	230	57	63	42°

IMPORTANT: Do not re-tighten the fixed end or adaptor after tightening the swivel nut. This will cause tension or torsion with can result in rapid deterioration.

INSPECTION: We recommend a good maintenance practice and periodic inspections, typically when servicing other components at the unit or at the installation site. Check all hoses for small water leaks, residue, or discoloration on the exterior braid and fittings. If a leak is detected, stop service to the unit and replace hose immediately. Do not attempt to repair the hose.

Caution: Introduction of chemicals into the system or unit may cause damage of the inner core of the hose. Consult a water treatment specialist for chemical compatibility before using any chemical additives.

Warning: Hoses are designed for Hydronic heating and cooling service only; not for gas.

Warranty

Warranty Information

For a period of five years from the date of shipment, the company warrants each product or system of its own manufacture to the original purchaser to be free from defects in material and workmanship under normal use, service and maintenance. Normal use, service and maintenance means:

- A. Not in excess of the maximum pressures, temperatures, volumes and rated capacities or other parameters specified in the company's product bulletins, specifications sheets, and/or quotations.
- B. Using only fluids specified in the company's product bulletins, specifications sheets, and/or quotations.
- C. Operation and maintenance in compliance with the appropriate instructions and/or information guides.

For complete details, please consult our warranty statement at www.jomarhydronics.com/resources.html

Replacement Guides

EPDM Flat Washer for Union Seal on Terminator A, S & Y

*Please print this page actual size for accurate scale

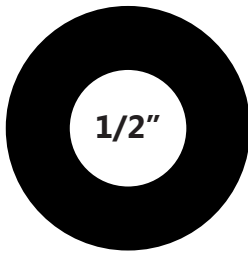

UG-A

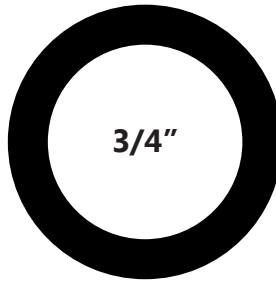

UG-B

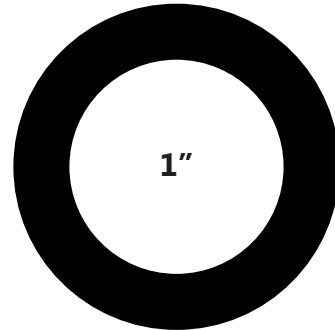

UG-C

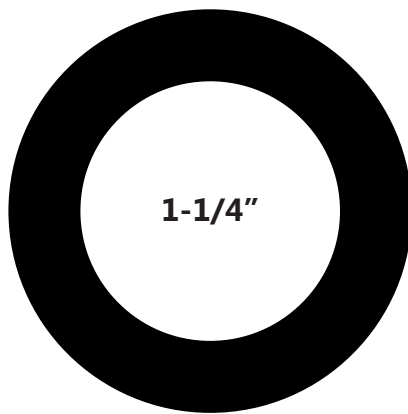

UG-D

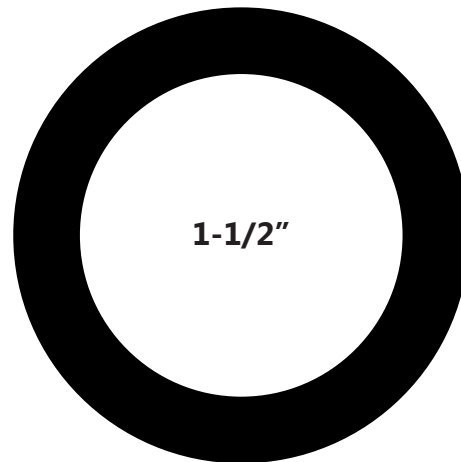

UG-E

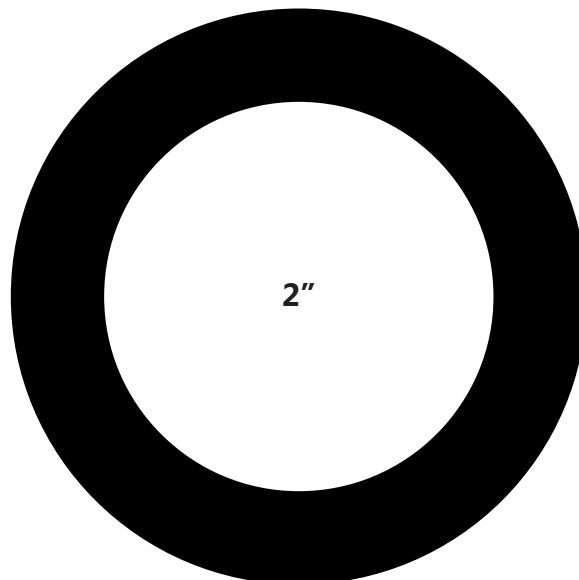

UG-F

Viton O-rings for Union Seal on Terminator and Terminator B

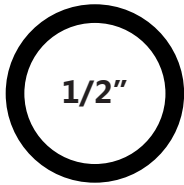

VOR-A

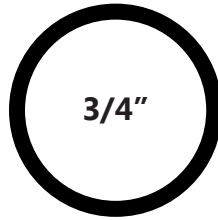

VOR-B

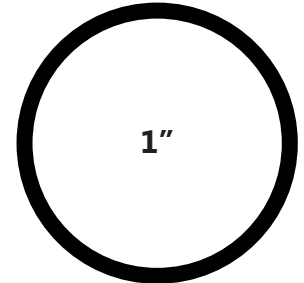

VOR-C

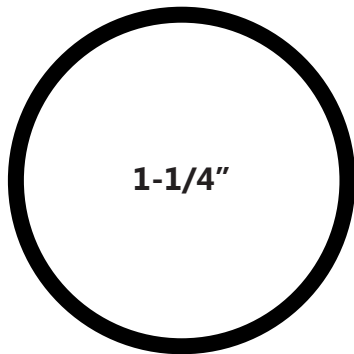

VOR-D

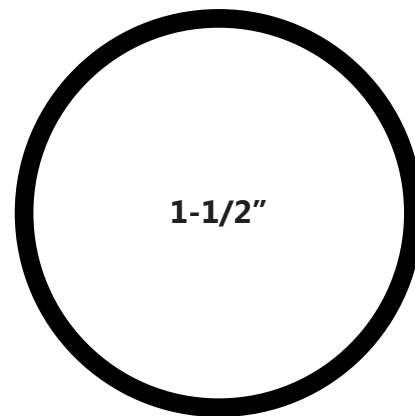

VOR-E

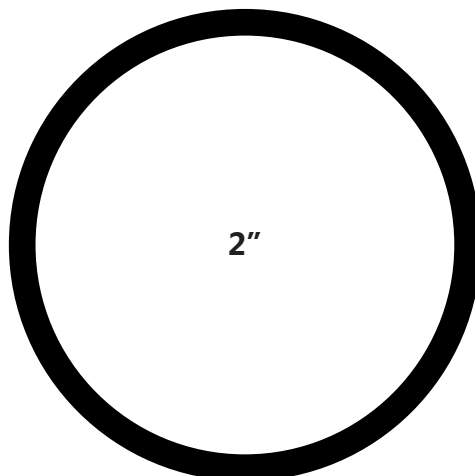

VOR-F