

Terminator PICV

Technical Manual



Table of Contents

Introduction.....	1
Advantages and Ease of Use.....	1
Applications examples.....	2
Technical specifications.....	3
Start Up Charts.....	6
Start Up Charts.....	7
Start Up Charts.....	8
Flow Pre-setting.....	9
Flow setting accuracy.....	9
Flow control and characteristic curves.....	10
Installation and Maintenance.....	15
Installation and maintenance - Terminator PICV - 91 Series.....	16
Installation and maintenance - Terminator PICV - 93 Series.....	17
Installation and maintenance - Terminator PICV - 85 Series.....	18
Installation and maintenance - Terminator PICV - 94F Series.....	20
SMART actuators for 94F series.....	21
91 TerminatorPICV dimensional data.....	22
93 TerminatorPICV dimensional data.....	22
85 TerminatorPICV dimensional data.....	23
94F TerminatorPICV dimensional data.....	24
TerminatorPICV shipping weight information.....	24

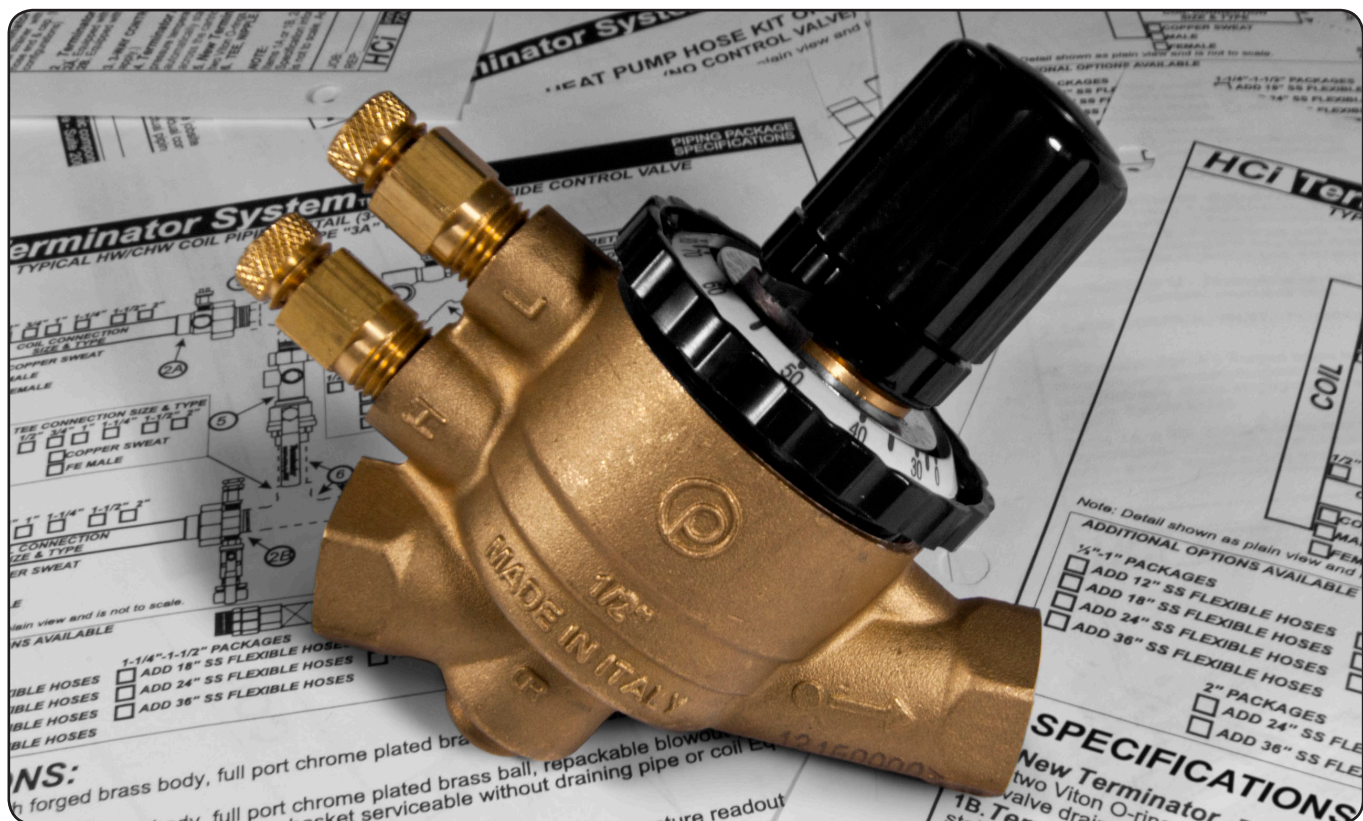

Introduction

The **TerminatorPICV** (Pressure Independent Control Valve) is a combined constant flow limiter and full stroke, full authority temperature control valve.

The **TerminatorPICV** is suitable for use in variable and constant temperature systems and may be used as constant flow limiter in constant volume systems (without an actuator head) or as a true PICV in variable volume systems.

Operating principle

TerminatorPICV valve is made by three main parts:

1. Differential Pressure Regulator
2. Control Valve
3. Flow Pre-Setting Knob

1. Differential pressure regulator

The differential pressure regulator is the heart of the pressure independent control valve. By keeping a constant differential pressure across the control valve, constant flow and full authority temperature control can be achieved.

Incoming pressure P1 is transmitted to the top face of the diaphragm, outgoing pressure P3 is transmitted to the underside of this same diaphragm. A constant effective differential pressure is maintained between P2 and P3. As P1 increases relative to P3 it acts on the diaphragm closing the shutter (A) against a seat (B) thereby lowering the effective differential pressure. As P1 decreases relative to P3 the diaphragm acts to open the shutter (A) from the seat (B) thus increasing the effective differential pressure. The diaphragm acts against a spring in order to balance the pressure control and stop the diaphragm oscillating.

2. Control Valve

Water flow through a valve varies as a function of the area of passage and the pressure differential across that valve. Due to the incorporation of the differential pressure regulator the differential across the control valve P2 – P3 is constant meaning that flow is only a function of area of passage. Setting any flow rate value and maintaining it stable is also possible.

Advantages and Ease of Use

1. Advantages

- **TerminatorPICV** is a full authority temperature control valve. This means that each terminal receives the exact flow required even in part load conditions.
- The regulator corrects any differential pressure variation. This leads to a considerable reduction in temperature variations and adjustment movements and to the extension of the life of the control valve actuator.
- **TerminatorPICV** valves offer a remarkable adjustment flexibility. They can be accurately set to a specific flow rate value and they allow precise modulating control.
- Since the **TerminatorPICV** performs the functions of two valves (balancing and adjustment), the installation costs are considerably reduced.
- The automatic flow rate limitation drastically reduces system commissioning costs.
- Design flow rates can be modified at any time and at low costs.
- After its installation, the valve can work immediately. For example, on the floors where works are already finished.

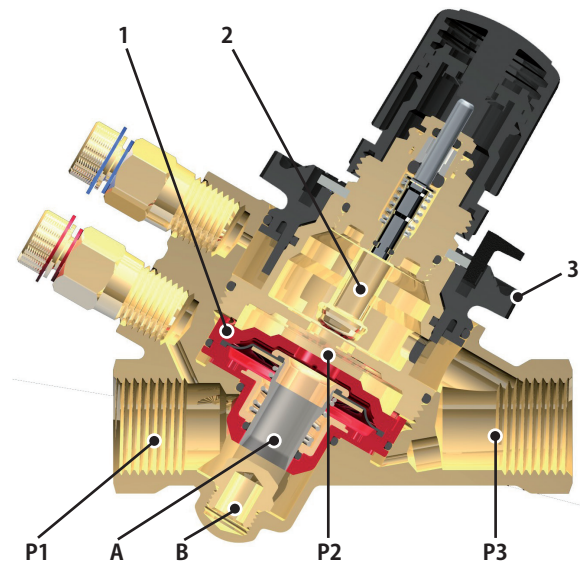

Functional schematic

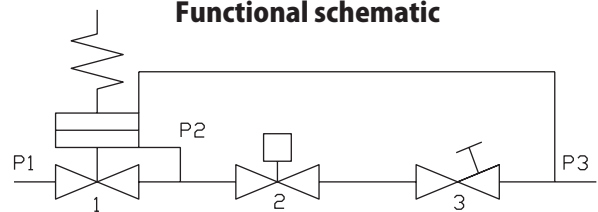

3. Adjustment knob

The maximum flow can be preset, choking the outlet section of the control valve, using the graduated adjustment knob. The percentage value, indicated on the scale, matches the maximum flow rate percentage. This value can be changed turning the adjustment knob until it reaches the selected position (matching the percentage indicated on the scale). A locking mechanism avoids the valve set values from being changed inadvertently.

2. User-friendliness

- In order to adjust the flow rate, just set the selected value using the adjustment knob.
- Flow rate is the only parameter to be considered, choosing the suitable valve is easy and fast.
- Setting ratio calculation is not necessary.
- Valve authority calculation is not required.
- Specific devices or knowledge are not necessary.
- Compact design that allows installation of the valve in small spaces such as fan-coils or narrow supply spaces.
- The special adjustment knob allows the flow rate to be set without disassembling the actuator.

Applications examples

1. 2-Way piping applications

The use of the PICV as both the flow limiting device and the control valve ensures stable flow to the terminal unit, and full authority to the control valve. This allows the terminal unit to work at its maximum efficiency while operating independently from the rest of the system, provided the minimum start up pressure for the PICV is met. The necessary steps must be taken to ensure proper flushing, as shown below.

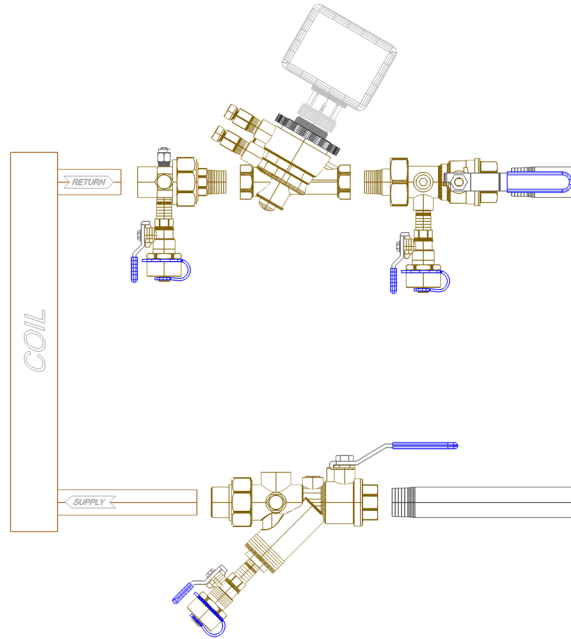

2. 3-Way piping applications

The three way control valve design provides independent temperature control, while the PICV acts as a flow limiting device ensuring stable flow to the terminal unit. Once again, the PICV allows the terminal unit to operating independently from the rest of the system, provided the minimum start up pressure for the PICV is met. Below is a recommending piping design

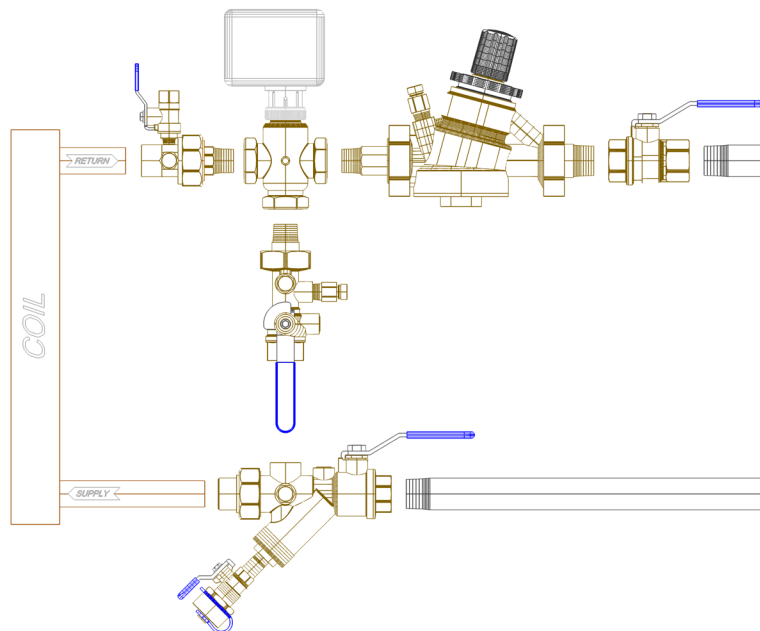

3. Single pipe applications

The use of the PICV as a flow limiting device on single pipe systems ensures stable flow to banks of radiators or baseboards. If the single pipe system is part of a larger design which uses PICV's to control terminal units. It is good practice to use PICV's on the single pipe sub system as well. This ensures flow resistances is the same for all terminal units.

Technical specifications

Terminator PICV - 91 Series

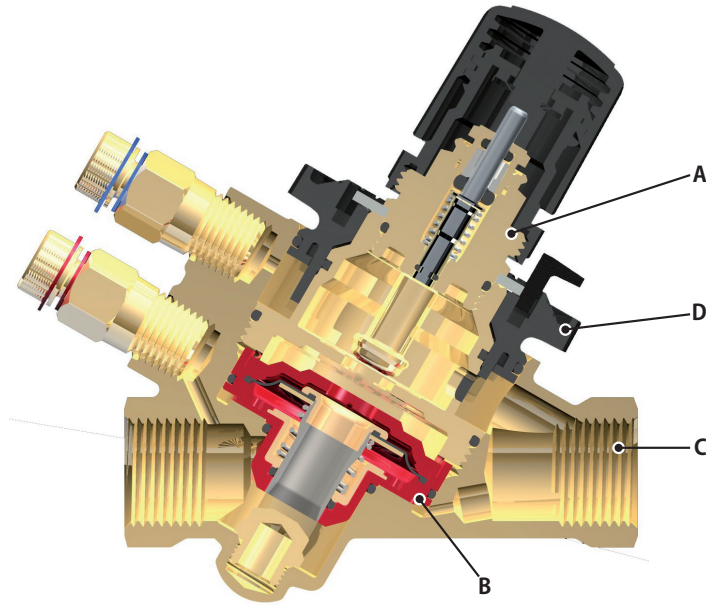

Material list

Regulating valve (A)	Brass CW614N Stainless steel 18/8
Cartridge (B)	High resistance polymer - EPDM Stainless steel AISI 303
Presetting (D)	High resistance polymer Brass CW614N
Body (C)	Brass CW602N
Gaskets	EPDM-x

ΔP Max.	Temperature	Working pressure max.	Stroke	Rangeability	Leakage
58 PSI	14 - 248 °F	362 PSI	2.7 mm	50 - 100	ANSI Class IV
	T91-AFF-0.66	T91-AFF-2.64	T91-AFF-3.43	T91-BFF-4.40	T91-BFF-6.60
Flow rate max.	0.66 GPM	2.64 GPM	3.43 GPM	4.40 GPM	6.60 GPM
Start-up max.	2.90 PSI	3.63 PSI	3.63 PSI	4.35 PSI	5.08 PSI
Connections	1/2" FNPT	1/2" FNPT	1/2" FNPT	3/4" FNPT	3/4" FNPT

Terminator PICV - 93 Series

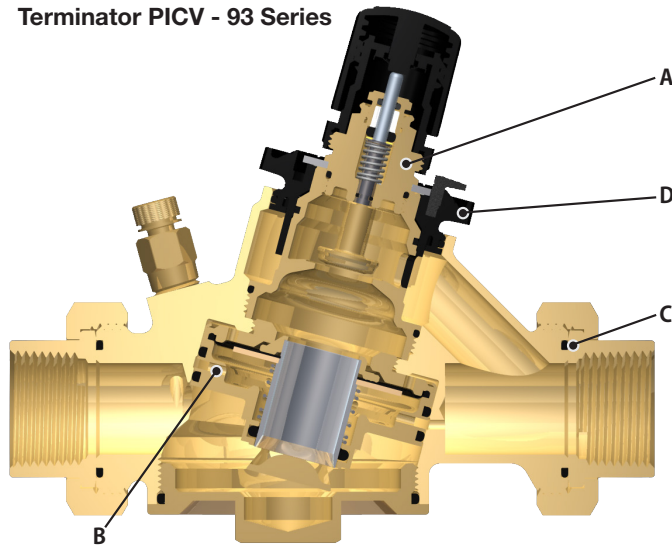

Material list

Regulating valve (A)	Brass CW614N Stainless steel 18/8
Cartridge (B)	Brass CW614N - EPDM Stainless steel AISI 303
Presetting (D)	High resistance polymer Brass CW614N
Body (C)	Brass CW602N
Gaskets	EPDM-x

ΔP max.	Temperature	Working pressure max.	Stroke	Rangeability	Leakage
58 PSI	14 - 248 °F	362 PSI	6.0 mm	100 - 150	ANSI Class IV
		T93-___-9.68	T93-___-11.9		T93-___-13.2
Flow rate max.		9.68 GPM	11.9 GPM		13.2 GPM
Start-up max.		3.63 PSI	3.63 PSI		5.08 PSI
Connections		Union: 3/4" - 1"	Union: 3/4" - 1 1/4"		Union: 3/4" - 1 1/4"

Technical specifications

Terminator PICV - 85 Series

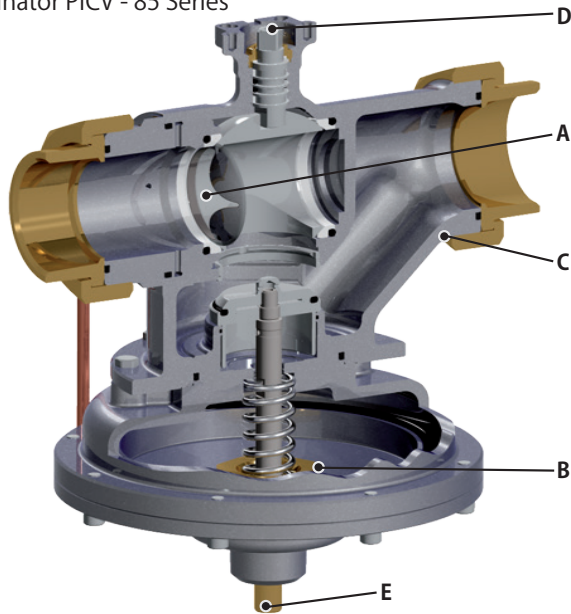

Material list

Regulating valve (A)	Brass CW602N Stainless steel 18/8
Cartridge (B)	High resistance polymer - EPDM Stainless steel AISI 303
Presetting (D)	Brass CW602N
Body (C)	Ductile Iron
Gaskets	EPDM-x
Additional manual shut-off device (E)	Brass CW614N

ΔP max.	Temperature	Working pressure max.	Stroke	Rangeability	Leakage
58 PSI	14 - 248 °F	232 PSI	90°	>100	ANSI Class IV
		T85-___-39.6	T85-___-52.8	T85-___-79.3	
Flow rate max.		39.6 GPM	52.8 GPM	79.3 GPM	
Start-up max.		3.63 PSI	3.63 PSI	5.08 PSI	
Connections		Union: 1 1/4" - 1 1/2"	Union: 1 1/2" - 2"	Union: 2" - 2 1/2"	

Terminator PICV - 94F Series

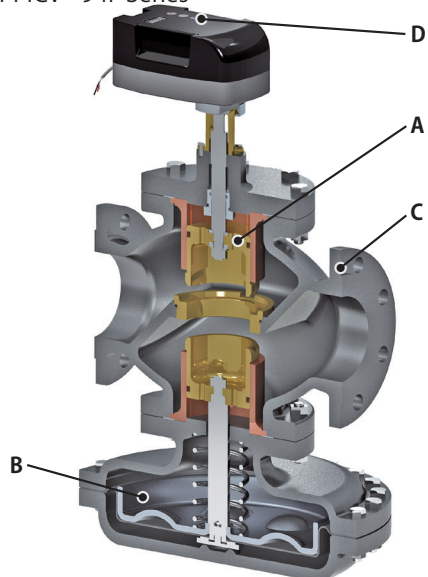

Material list

Regulating valve (A)	Brass CW602N Stainless steel 18/8
Cartridge (B)	Brass CW602N - EPDM Stainless steel AISI 303
Presetting (D)	High resistance polymer Brass CW602N
Body (C)	Ductile iron
Gaskets	EPDM-x

ΔP max.	Temperature	Working pressure max.	Stroke	Rangeability	Leakage	
58 PSI	14 - 248 °F	232 PSI	15 - 22 mm	>100	ANSI Class IV	
		T94F-FFF-88.1	T94F-GFF-132	T94F-HFF-176	T94F-IFF-242	T94F-JFF-660
Flow rate max.	88.1 GPM	132 GPM	176 GPM	242 GPM	660 GPM	
Start-up max.	4.35 PSI	4.35 PSI	4.35 PSI	4.35 PSI	7.25 PSI	
Connections	2" Flange	2 1/2" Flange	3" Flange	4" Flange	6" Flange	

Dynamic characteristic curves

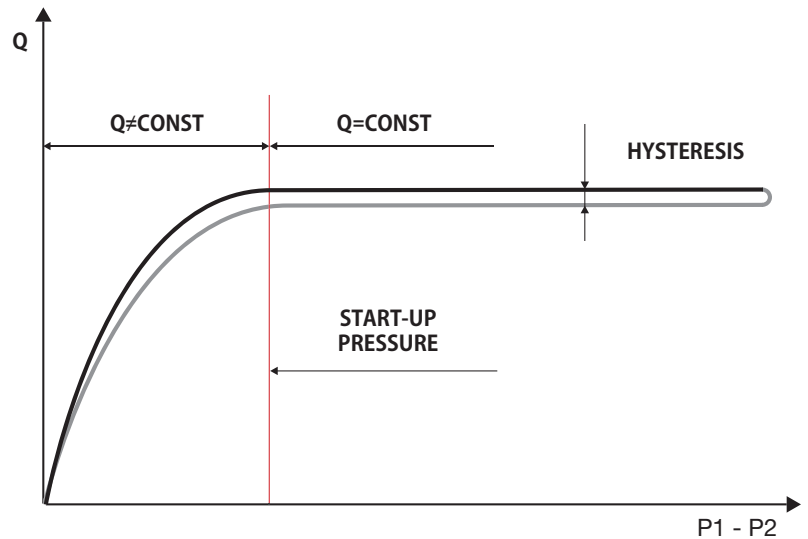
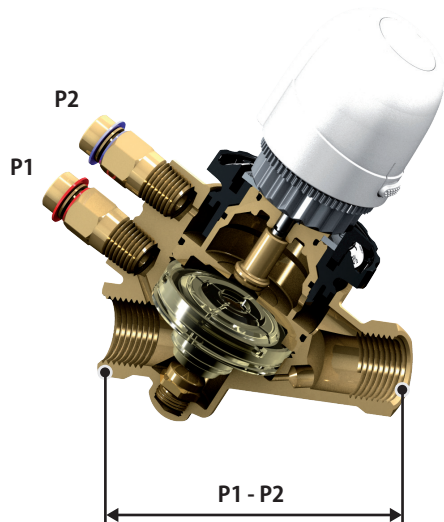

Using a differential pressure gauge to measure the pressure drop the valve absorbs, allows to check whether the valve is in the operating range (and, therefore, whether the flow is constant) by simply verifying that the measured value $P1 - P2$ is higher than the start-up value.

If the ΔP measured value is lower than the start-up value, then the valve works as a fixed orifice valve. Start-up value varies with flow setting of the valve, as shown by the example below:

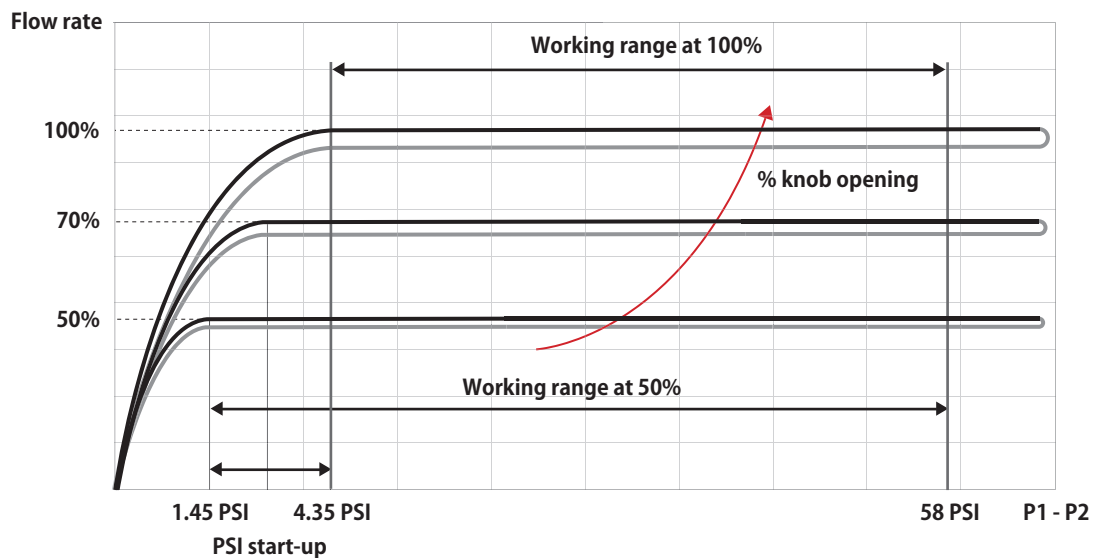

When the valve is set at 100% of nominal (maximum) flow, the curve begins to remain constant at 4.35 PSI therefore the working range of the valve is 4.35 - 58 PSI;

When the valve is set at 50% of nominal flow, the curve begins to remain constant at 1.45 PSI, therefore the working range of the valve is 1.45 - 58 PSI.

Start Up Charts

The following charts show how *start-up pressure* changes for each model

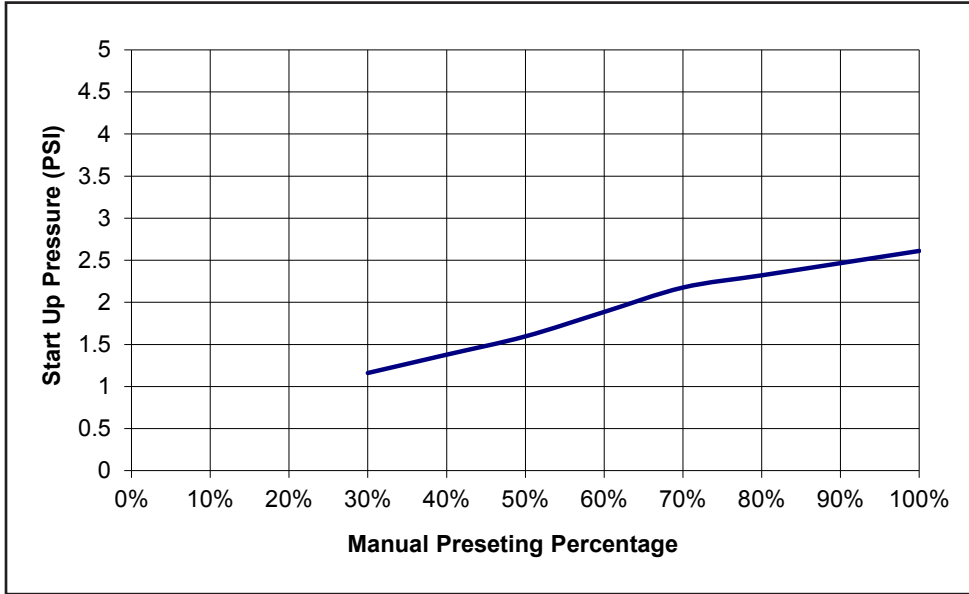

Valve model

T91-AFF-0.66

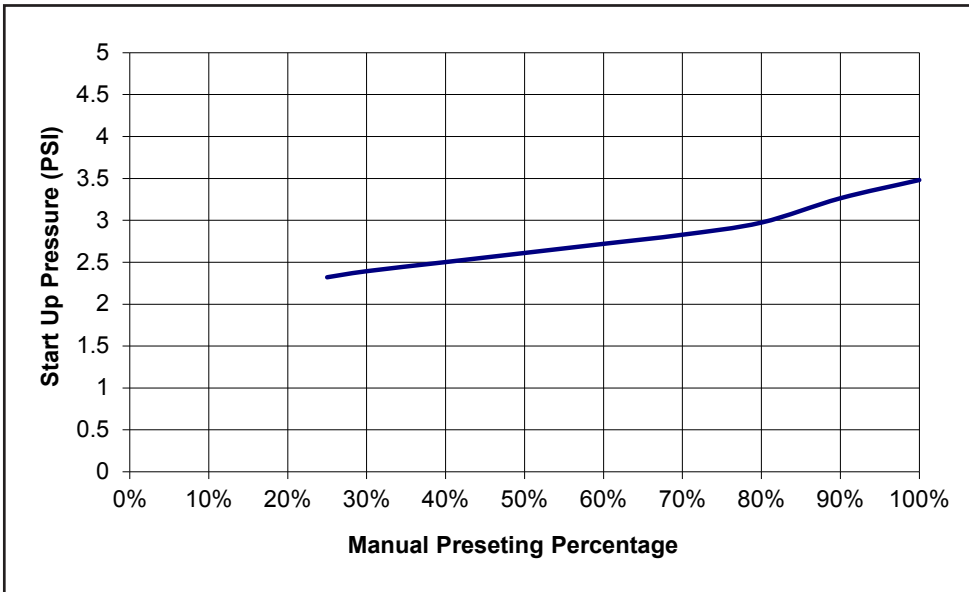

Valve model

T91-AFF-2.64

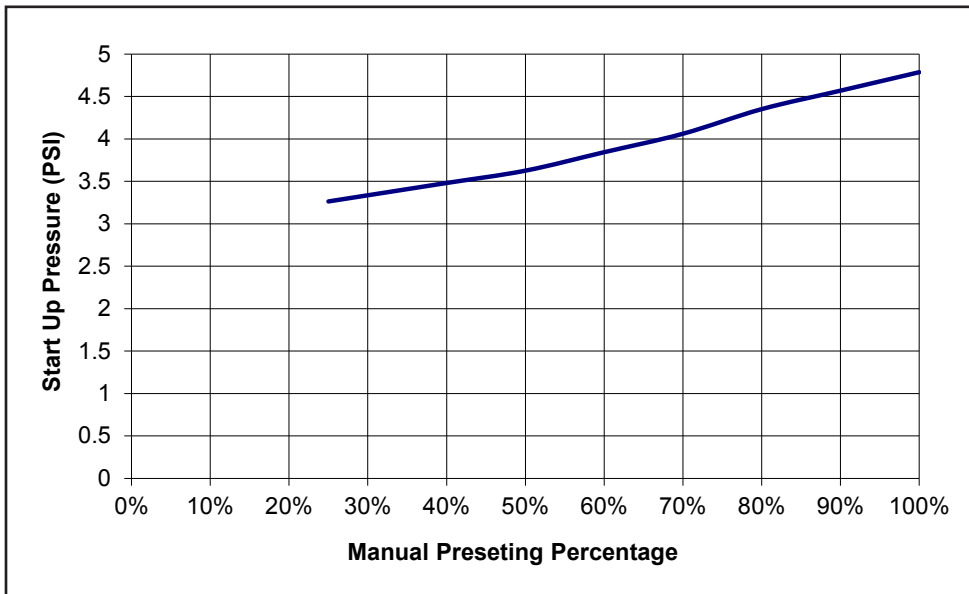

Valve model

T91-AFF-3.43



Start Up Charts

The following charts show how *start-up pressure* changes for each model

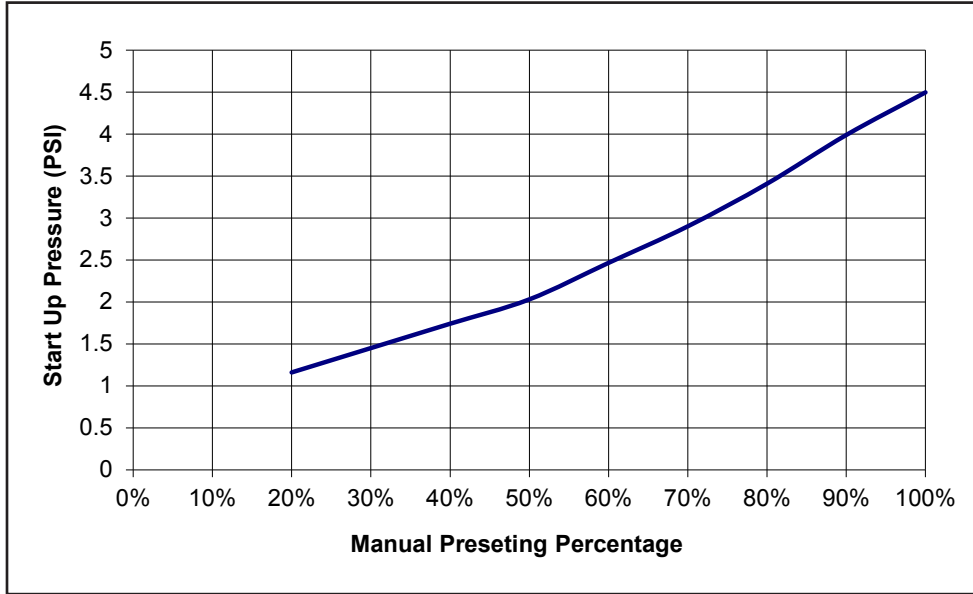

Valve model

T91-BFF-4.40

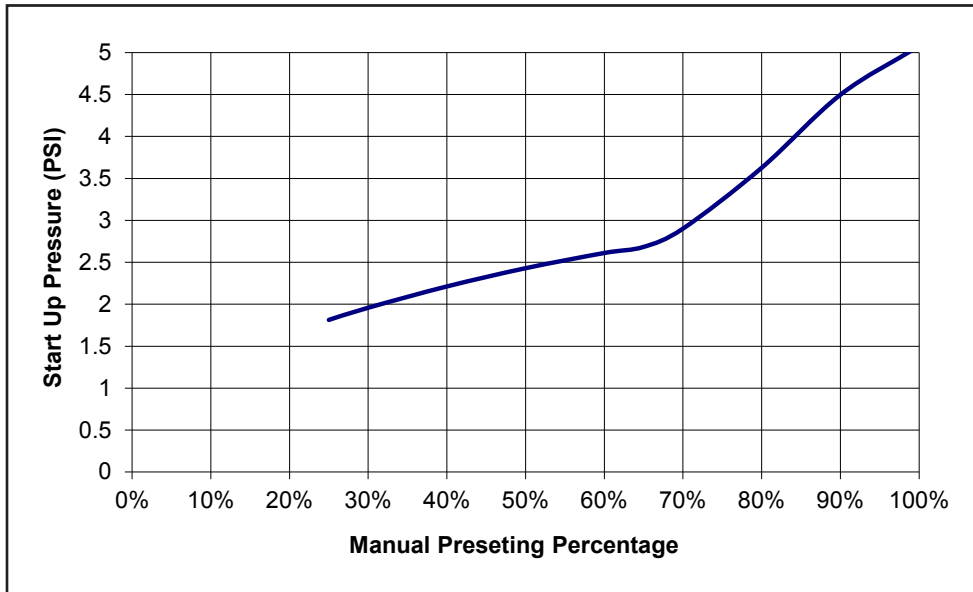

Valve model

T91-BFF-6.60

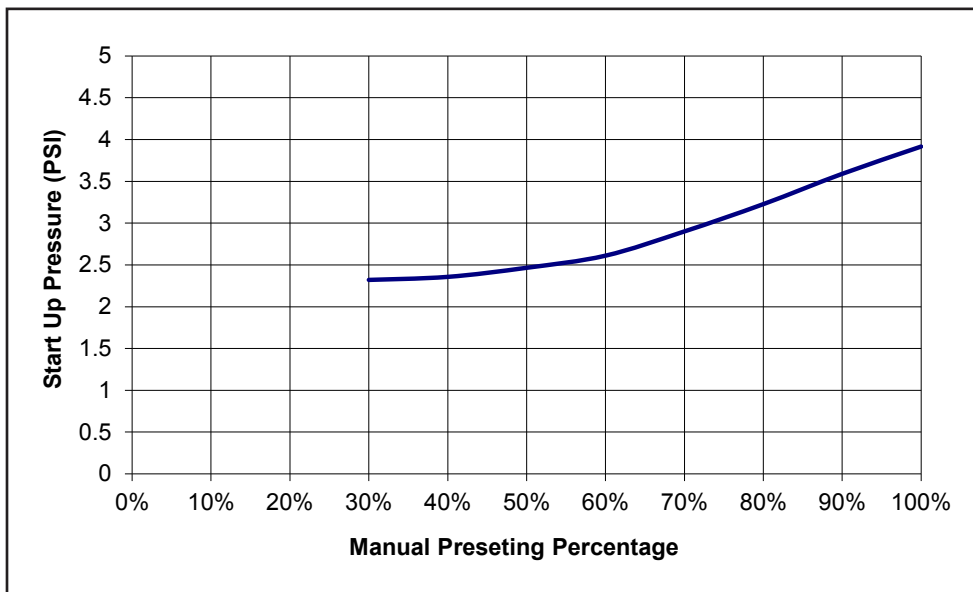

Valve model

T93-B_-9.68

T93-C_-9.68



Start Up Charts

The following charts show how *start-up pressure* changes for each model

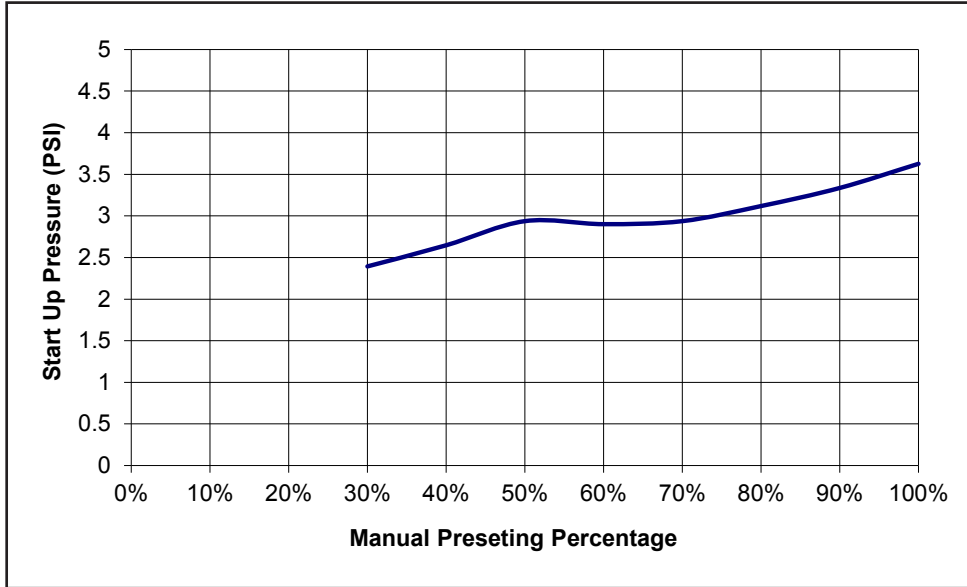

- Valve model**
- T93-B__-11.9
 - T93-C__-11.9
 - T93-D__-11.9

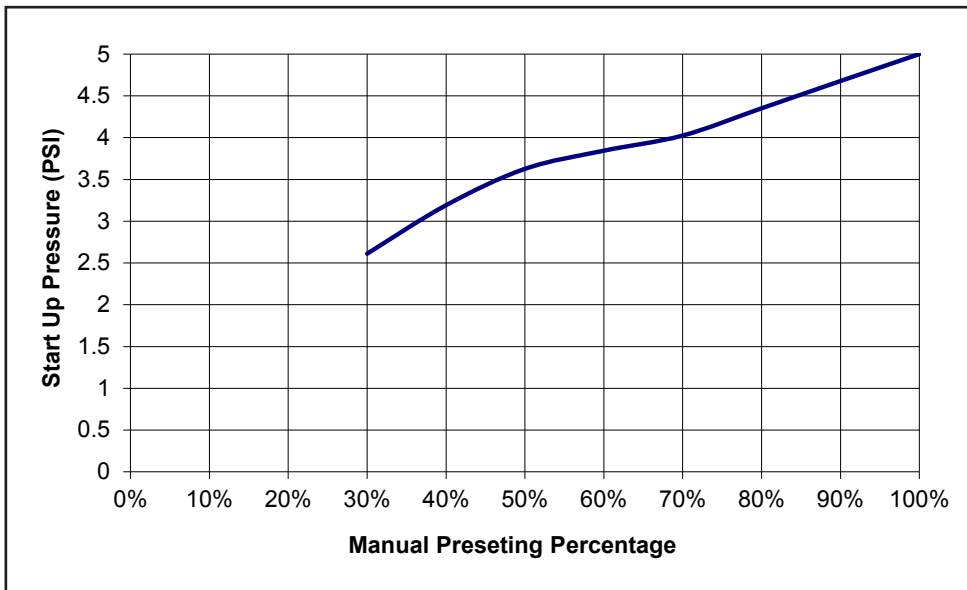

- Valve model**
- T93-B__-13.2
 - T93-C__-13.2
 - T93-D__-13.2

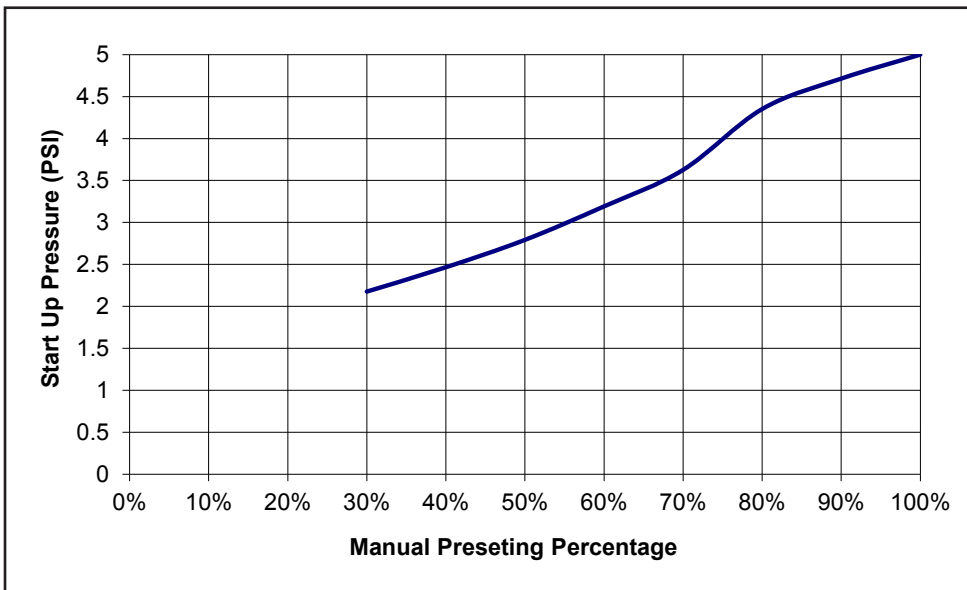

- Valve model**
- T85-F__-79.3



Flow Pre-setting

Flow pre-setting Terminator PICV - 91 Series

Presetting %	T91-AFF-0.66	T91-AFF-2.64	T91-AFF-3.43	T91-BFF-4.40	T91-BFF-6.60
	Flow Rate (GPM)	Flow Rate (GPM)	Flow Rate (GPM)	Flow Rate (GPM)	Flow Rate (GPM)
100	0.66	2.64	3.43	4.40	6.60
90	0.58	2.38	3.09	3.96	5.94
80	0.53	2.11	2.75	3.52	5.28
70	0.46	1.85	2.40	3.08	4.62
60	0.40	1.59	2.06	2.64	3.96
50	0.33	1.32	1.72	2.20	3.30
40	0.26	1.06	1.37	1.76	2.64
30	0.20	0.79	1.03	1.32	1.98
20	-	0.53	0.69	0.88	-
10	-	0.26	0.34	0.44	-

Flow pre-setting Terminator PICV - 93 Series

Presetting %	T93-___-9.68	T93-___-11.9	T93-___-13.2
	Flow Rate (GPM)	Flow Rate (GPM)	Flow Rate (GPM)
100	9.68	11.89	13.21
90	8.72	10.70	11.89
80	7.75	9.51	10.57
70	6.78	8.32	9.25
60	5.81	7.13	7.93
50	4.84	5.94	6.60
40	3.87	4.76	5.28
30	2.91	3.57	3.96
20	1.94	2.38	2.64
10	0.97	1.19	1.32

Flow pre-setting Terminator PICV - 85 Series

Presetting %	T85-___-39.6	T85-___-52.8	T85-___-79.3
	Flow Rate (GPM)	Flow Rate (GPM)	Flow Rate (GPM)
100	39.63	52.84	79.25
90	35.66	47.55	71.33
80	31.70	42.27	63.40
70	27.74	36.99	55.48
60	23.78	31.70	47.55
50	19.81	26.42	39.63
40	15.85	21.13	31.70
30	11.89	15.85	23.78
20	-	-	-
10	-	-	-

Flow pre-setting Terminator PICV - 94F Series

Presetting %	T94F-FFF-88.1	T94F-GFF-132	T94F-HFF-176	T94F-IFFF-242	T94F-JFF-660
	Flow Rate (GPM)	Flow Rate (GPM)	Flow Rate (GPM)	Flow Rate (GPM)	Flow Rate (GPM)
100	88.06	132.09	176.12	242.17	660.45
90	79.25	118.88	158.51	217.95	594.41
80	70.45	105.67	140.90	193.73	528.36
70	61.64	92.46	123.28	169.52	462.32
60	52.84	79.25	105.67	145.30	396.27
50	44.03	66.05	88.06	121.08	330.23
40	35.22	52.84	70.45	96.87	264.18
30	26.42	39.63	52.84	72.65	198.14
20	17.61	26.42	35.22	48.43	132.09
10	8.81	13.21	17.61	24.22	66.05

Flow setting accuracy

Max flow deviation at different settings

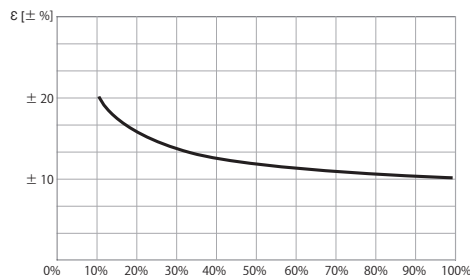

Flow control and characteristic curves

The characteristic of the control valve (ON/OFF, linear, equipercentage) should be chosen according to the heat exchanger and to the type of control to be performed on the system. For ON/OFF control, a valve with ON/OFF curve will be sufficient, while a modulating control requires a linear or equal percentage characteristic.

The following graphs show the optimal characteristic curve for the remote control of a heating / cooling system (A), the typical

curve of the terminal unit (B), the typical curves of the control valves of these systems (C) and, finally, the resulting curves (D), obtained joining the curve (B) with the different valve curves. As showed, the curve (D3), obtained combining an equal percentage valve with a terminal unit, corresponds to the optimal control curve (A).

(A) Optimal control characteristic of any heating / cooling system

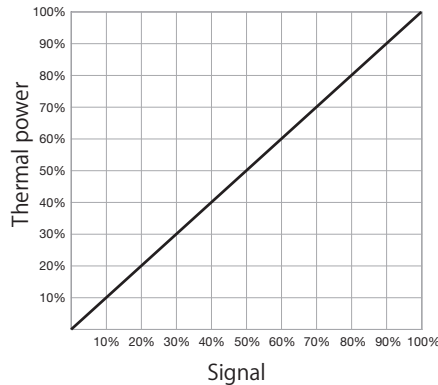

(B) Typical characteristic curve of a terminal unit

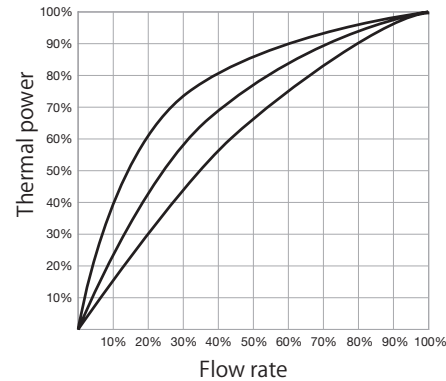

(C1) ON/OFF control valve characteristic curve

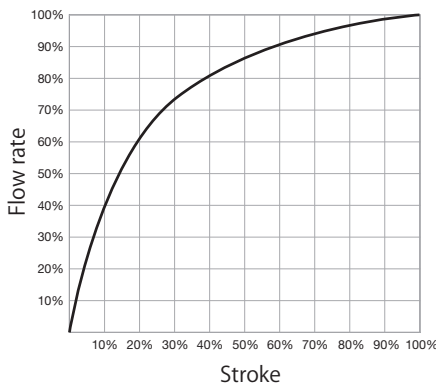

(C2) Linear control valve characteristic curve

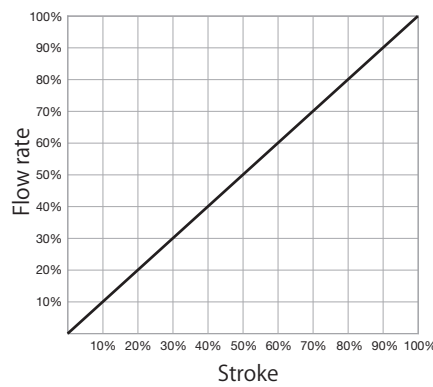

(C3) Equal percentage control valve characteristic curve

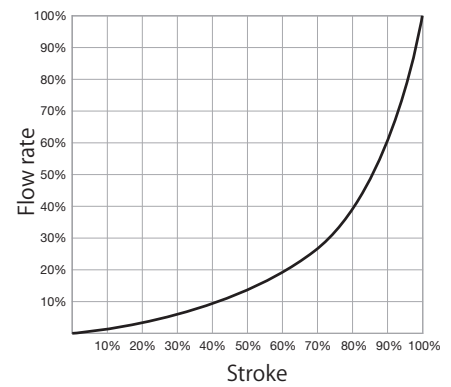

(D1) ON/OFF control valve + terminal unit resulting control characteristics

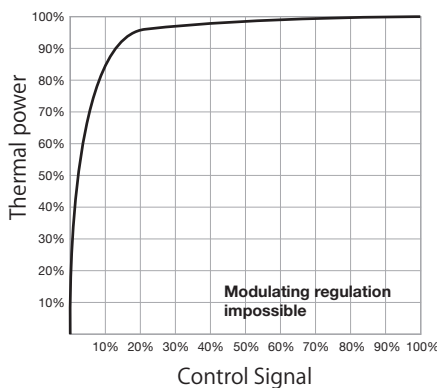

(D2) Linear valve + terminal unit resulting control characteristics

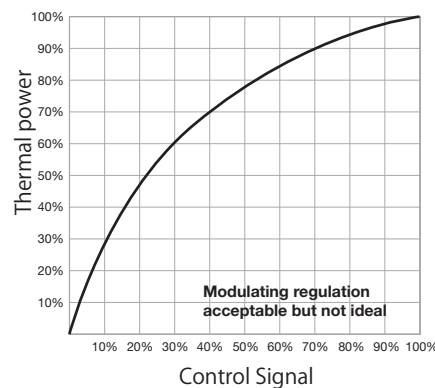

(D3) Equal percentage valve + terminal unit resulting control characteristics

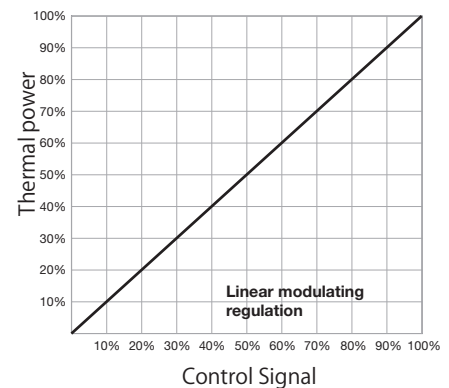

Combining the **TerminatorPICV** valve characteristic with heat exchanger results in a linear control system.

* Control curve characteristic may change according to valve version.

In the next pages, control curves for each valve model are shown.

All valves control characteristic have been tested and plotted according to VDI/VDE 2173 guidelines; the 01 and 93 series valves were driven by VA7482 (equal percent) 0-10V actuator.

Flow control and characteristic curves

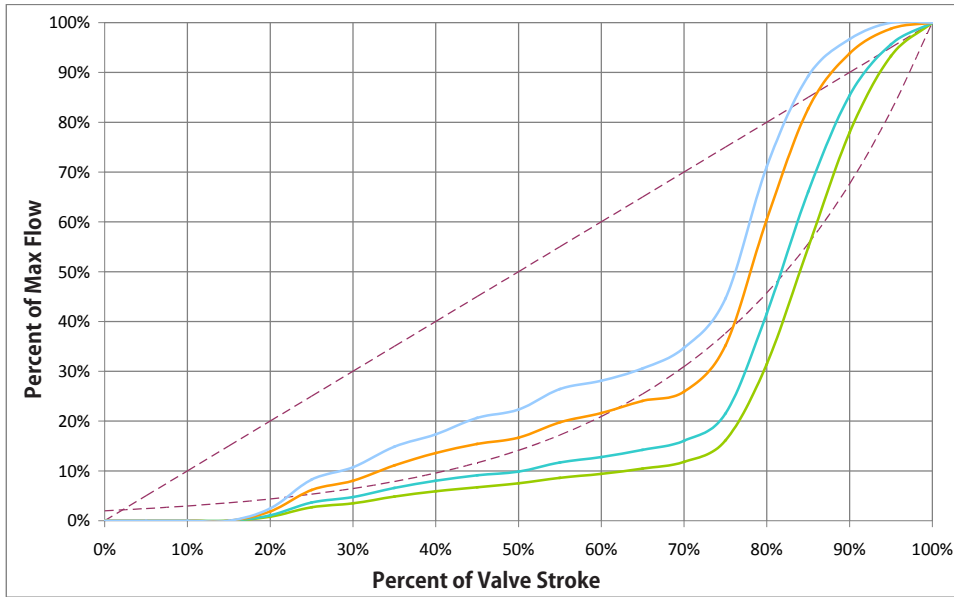

Valve model

T91-AFF-0.66

Presetting positions

- 100% Open
- 75% Open
- 50% Open
- 25% Open

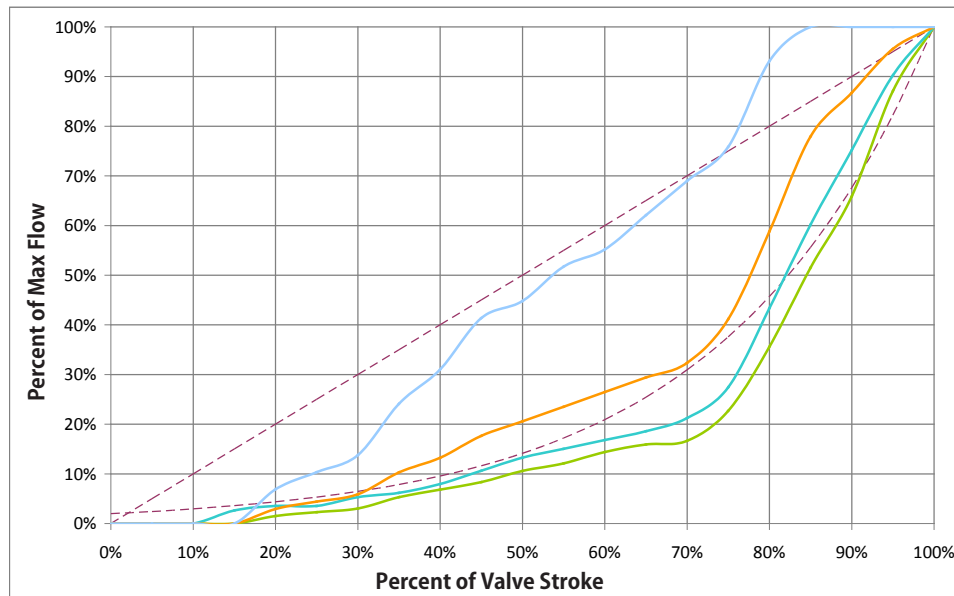

Valve model

T91-AFF-2.64

Presetting positions

- 100% Open
- 75% Open
- 50% Open
- 25% Open

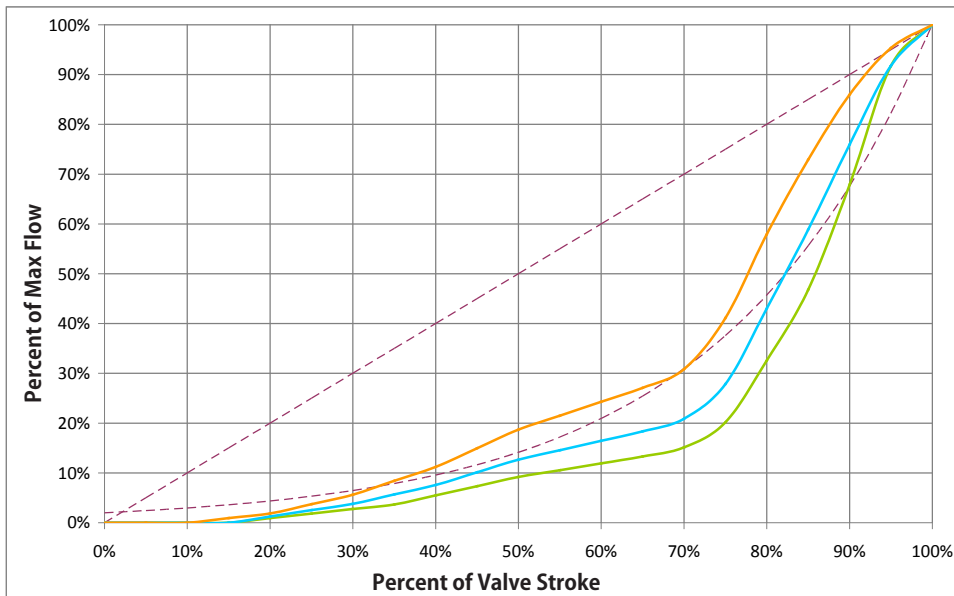

Valve model

T91-AFF-3.43

Presetting positions

- 100% Open
- 75% Open
- 50% Open

Flow control and characteristic curves

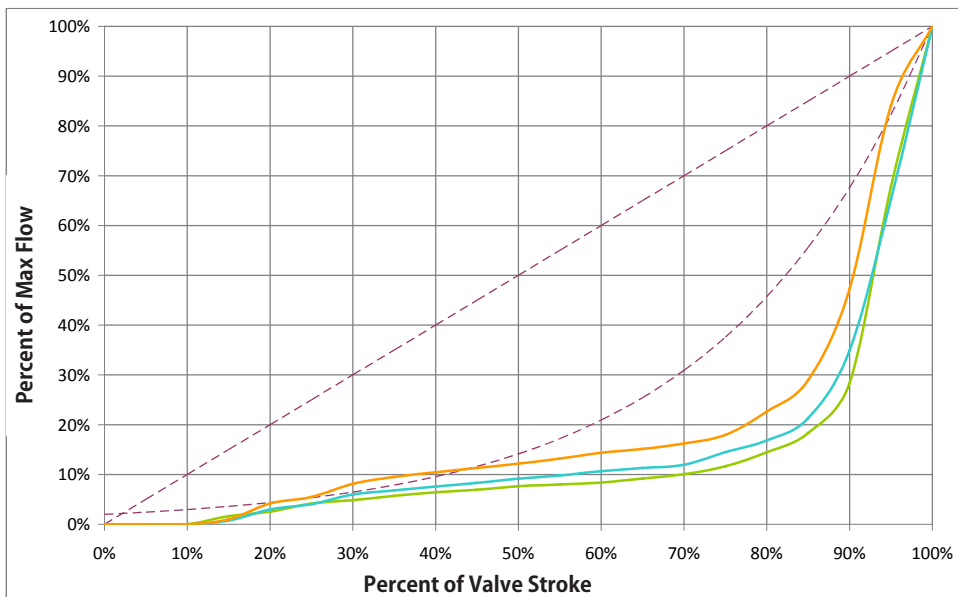
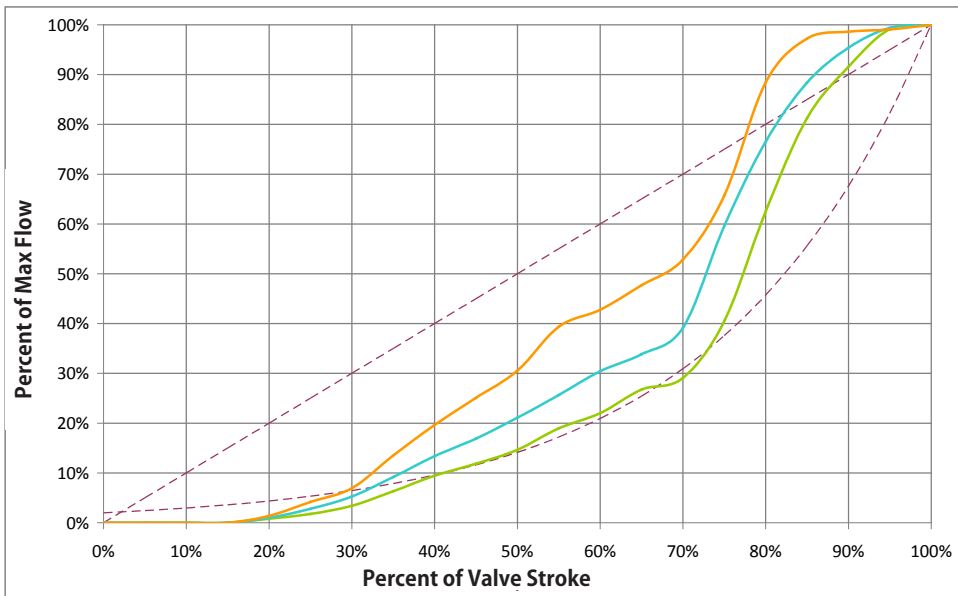
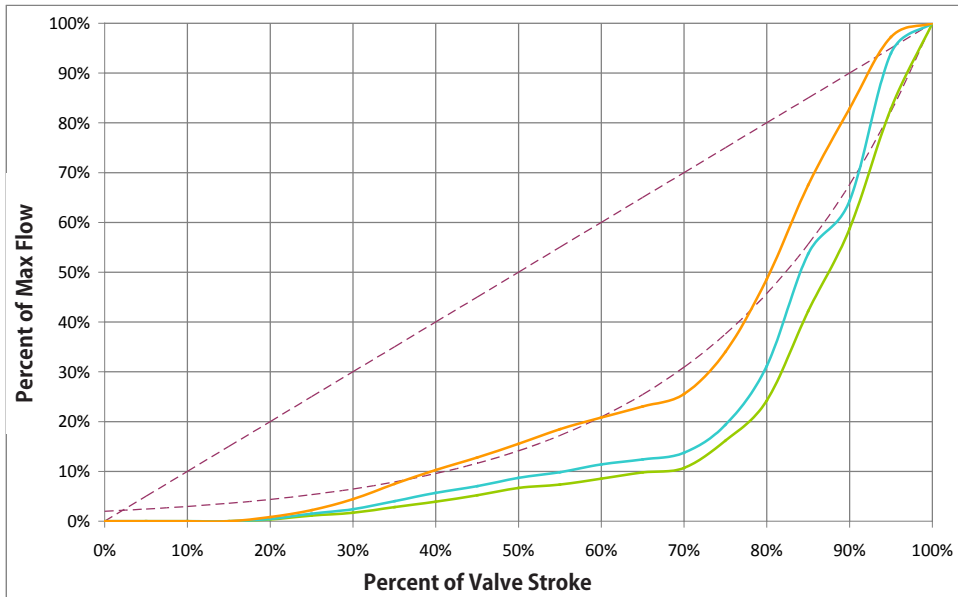

Flow control and characteristic curves

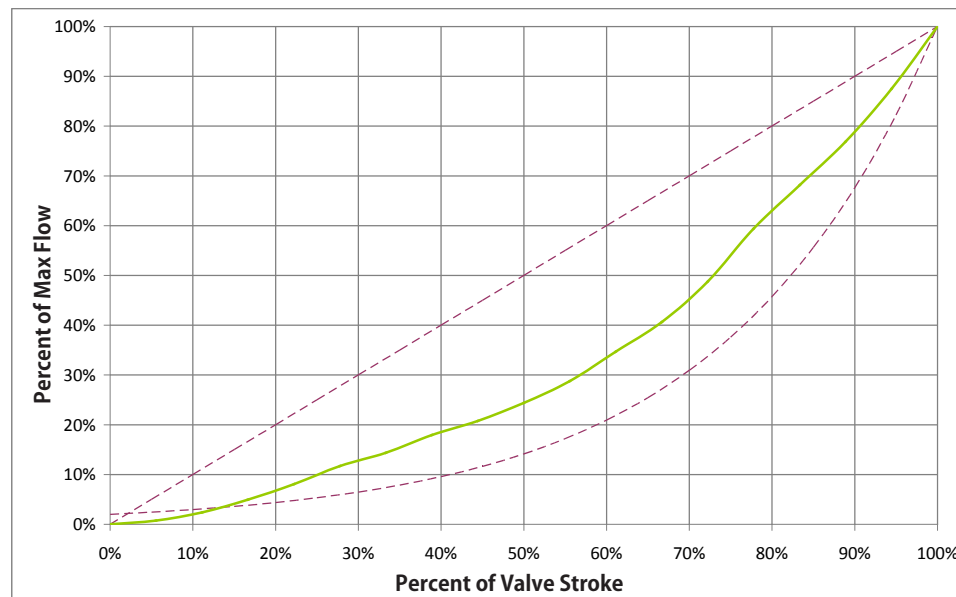
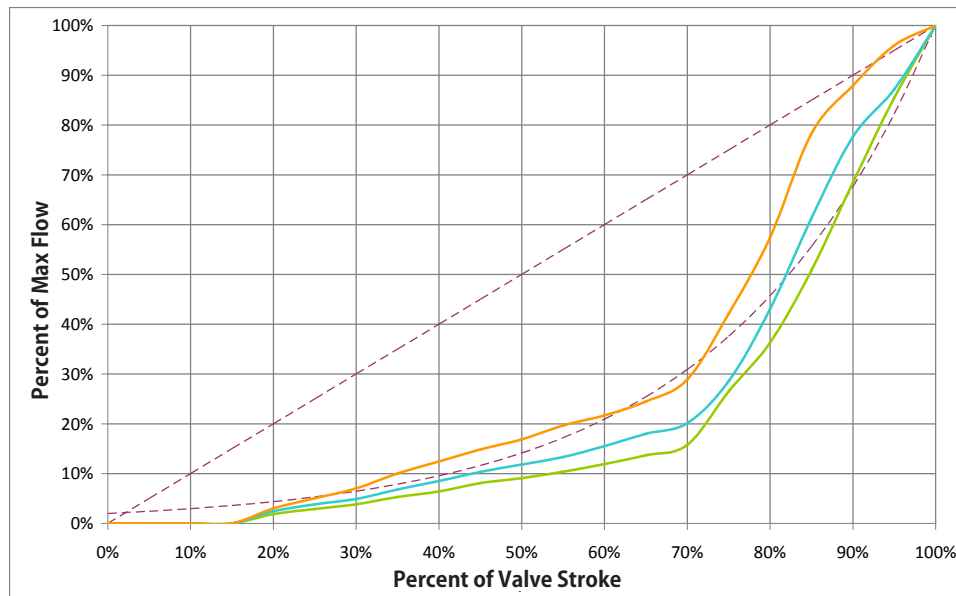
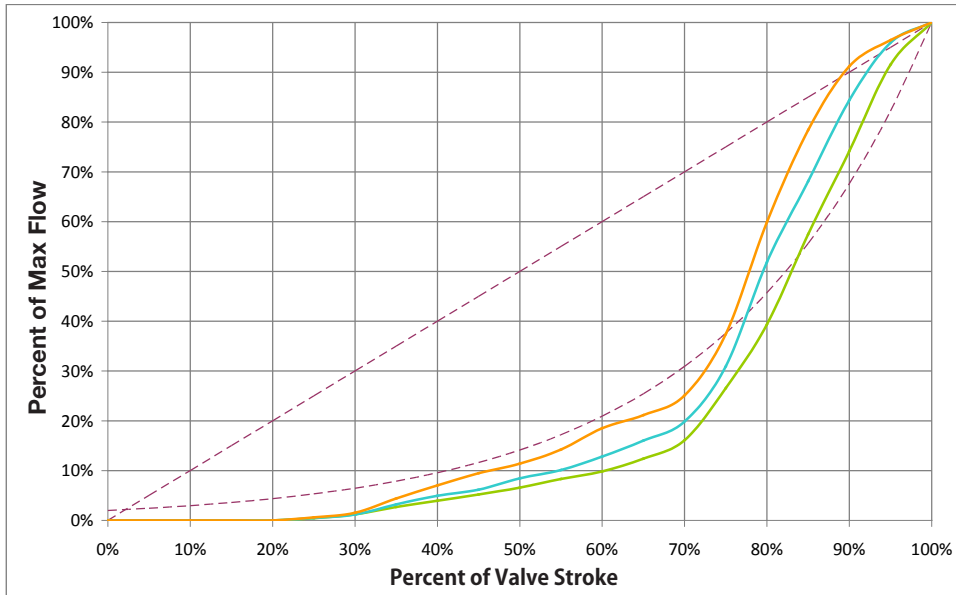

Flow control and characteristic curves

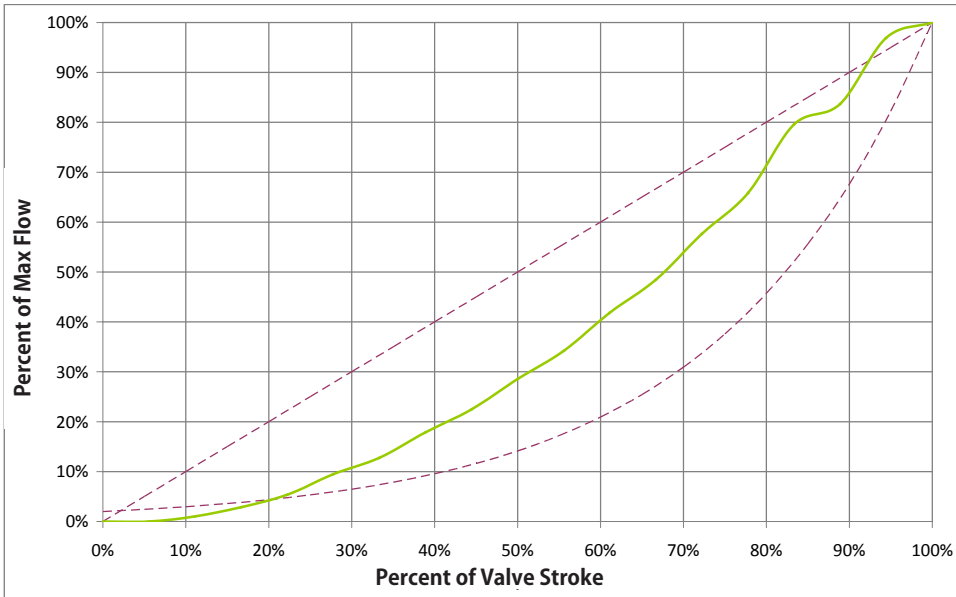

Valve model
T85-___-52.8

Presetting positions
— 100% Open

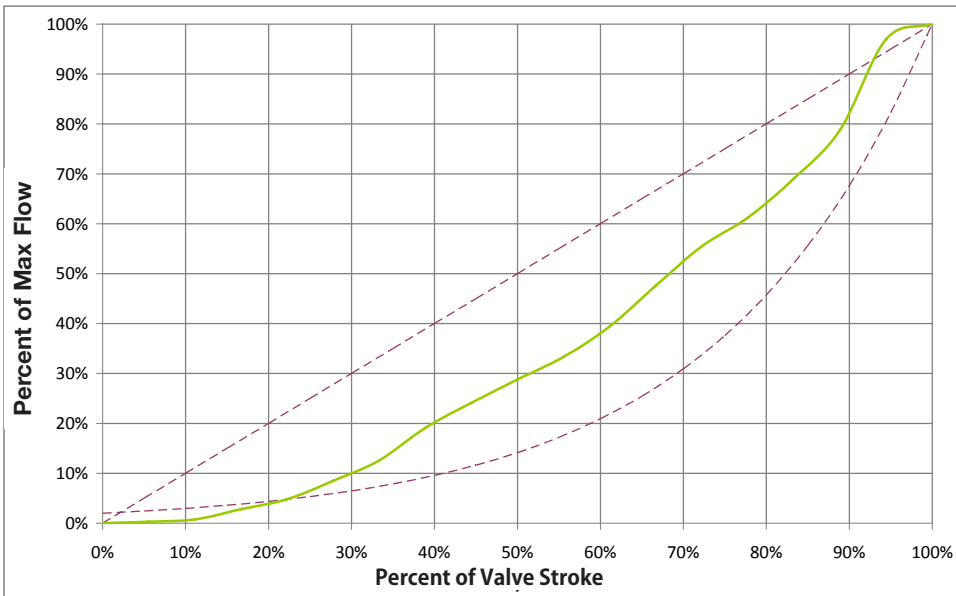

Valve model
T85-___-79.3

Presetting positions
— 100% Open

Installation and Maintenance

Before filling the terminal unit system with water, make sure main pipeline has been flushed and most of dirt and debris have been flushed away. Always comply with local or applicable flushing, however, in order to get the longest life and the best performance from a PICV, Jomar Hydraulics does not accept any liability for improper or wrong use of this product. Always protect the pressure regulator by using strainers upstream of the valve and make sure water quality complies with UNI 8065 standards (Fe < 0.5 mg/kg and Cu < 0.1 mg/Kg).

Furthermore, maximum iron oxide in the water passing through control valve (PICV) should not exceed 25 mg/Kg (25 ppm). To ensure the main pipework is cleaned appropriately, flushing by-passes should be used without flushing through the pressure regulator of the PICV thereby preventing debris that might clog the valve.

Here is an example, explaining the safest installation arrangement and filling/flushing methods:

Flushing of main pipe line

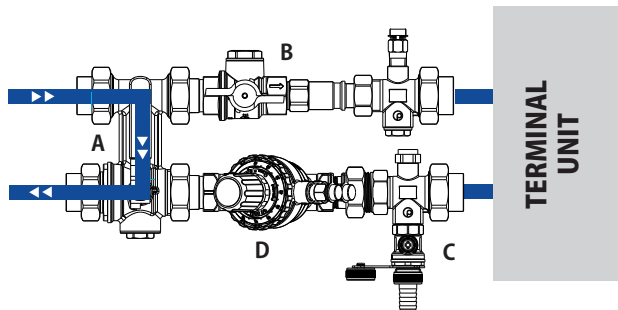

A: Bypass mode B: Closed C: Closed D: Open

Reverse back flushing

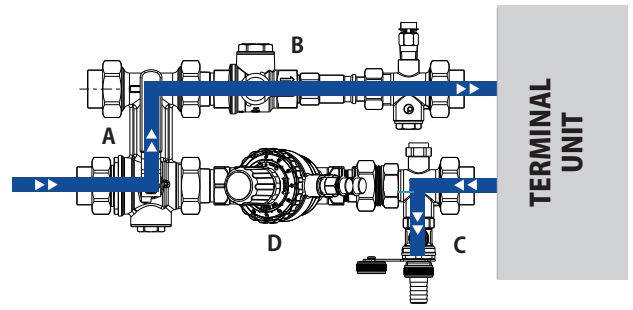

A: Bypass mode B: Open C: Open D: Closed

Direct back flushing

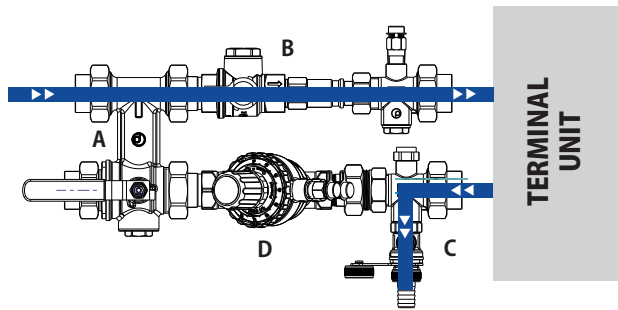

A: Normal mode B: Open C: Open D: Closed

Ready for commissioning

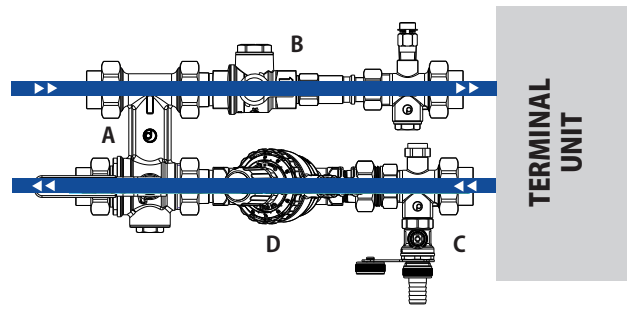

A: Normal mode B: Open C: Closed D: Open

Installation and maintenance - Terminator PICV - 91 Series

1. Use conditions

The valve has to be mounted with the arrow in the direction of the flow. Mounting it in the wrong direction may damage the system and the valve itself. If flow reversal is possible, a non-return valve should be mounted. Minimum differential pressure above which the valve begins to exercise its regulating effect:



	T91-AFF-0.66	T91-AFF-2.64	T91-AFF-3.43	T91-BFF-4.40	T91-BFF-6.60
Start-up ΔP	2.90 PSI	3.63 PSI	3.63 PSI	4.35 PSI	5.08 PSI
At 100% preset. See also pages 6-8					

2. Flow preset

To set the selected flow, follow these steps:

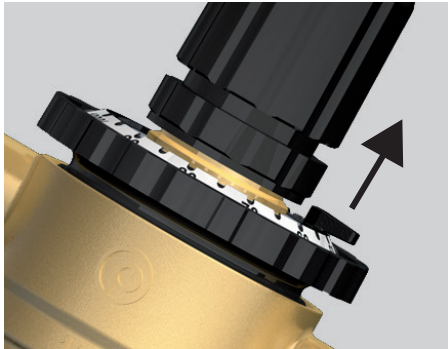

Lift the lock pin to unlock the selector



Turn the selector to the target position

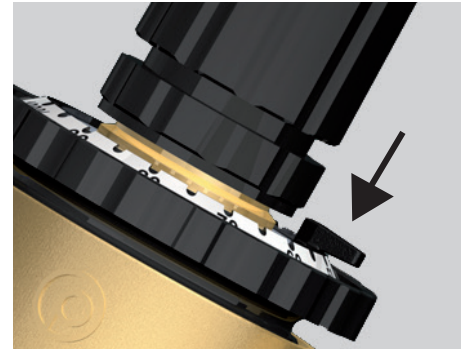

Press the lock pin to lock the selector in the final position

3. Operating control

It is necessary to be sure that the valve is working in the operating range. In order to verify it, measure the differential pressure across the valve, as shown in the picture. If the measured differential pressure is higher than the start-up pressure, the valve is keeping the flow constant at the set value.

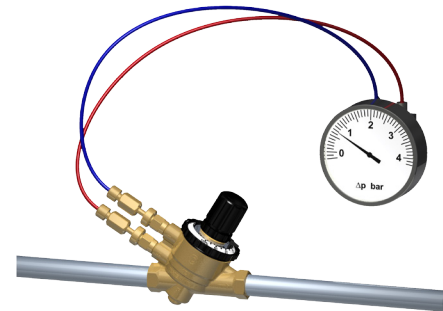

4. Maintenance and cleaning

During valve cleaning operations, use a damp cloth. DO NOT use any detergent or chemical product that may seriously damage or compromise the proper functioning and the reliability of the valve.

5. Actuator assembly

The valve can be equipped with a series of thermal-electric or electromechanical actuators, according to the requirements of the system. Actuators come along with an adaptor for proper mounting on the valve and for proper functioning of the whole device.

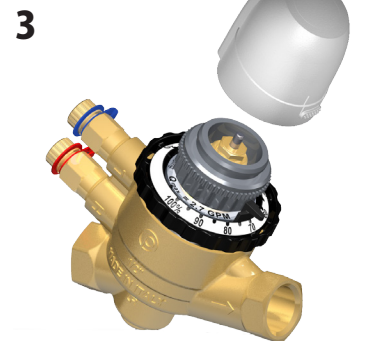
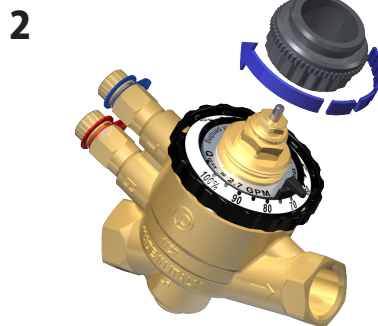
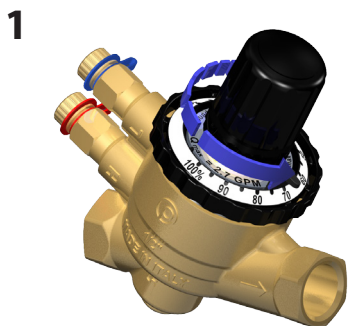

Installation and maintenance - Terminator PICV - 93 Series

1. Use conditions

The valve has to be mounted with the arrow in the direction of the flow. Mounting it in the wrong direction may damage the system and the valve itself. If flow reversal is possible, a non-return valve should be mounted. Minimum differential pressure above which the valve begins to exercise its regulating effect:

	T93-___-9.68	T93-___-11.9	T93-___-13.2
Start-up ΔP	3.63 PSI	3.63 PSI	5.08 PSI
At 100% preset. See also pages 6-8			



2. Flow preset

To set the selected flow, follow these steps:

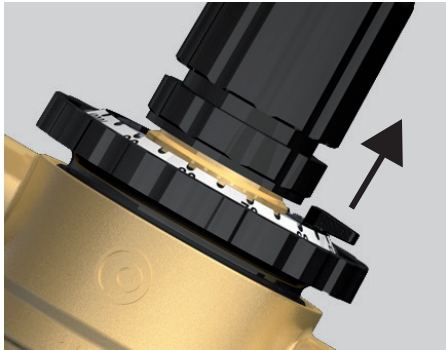

Lift the lock pin to unlock the selector

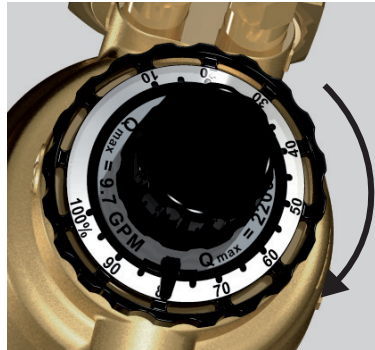

Turn the selector to the target position

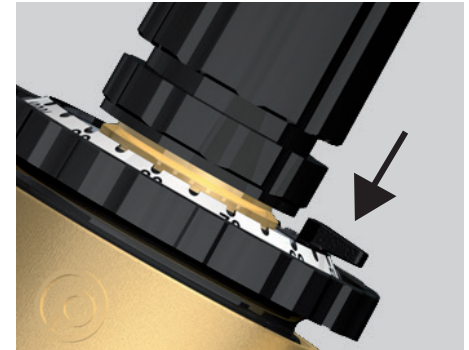

Press the lock pin to lock the selector in the final position

3. Operating control

It is necessary to be sure that the valve is working in the operating range. In order to verify it, measure the differential pressure across the valve, as shown in the picture. If the measured differential pressure is higher than the start-up pressure, the valve is keeping the flow constant at the set value.

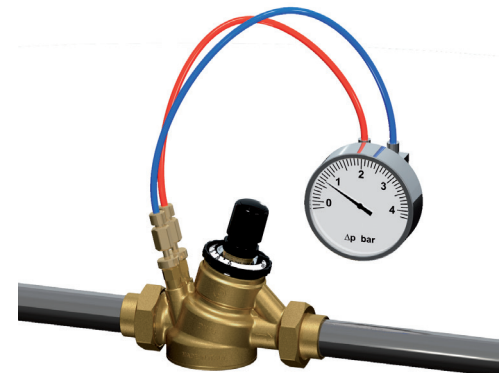

4. Maintenance and cleaning

During valve cleaning operations, use a damp cloth. DO NOT use any detergent or chemical product that may seriously damage or compromise the proper functioning and the reliability of the valve.

5. Cartridge replacement and flushing

If the cartridge (ΔP regulator) needs to be replaced or when flushing the pipework during pre-commissioning, instructions below:



1 Unscrew bottom cap using a 30mm socket



2 With an 32mm socket unscrew the ΔP regulator

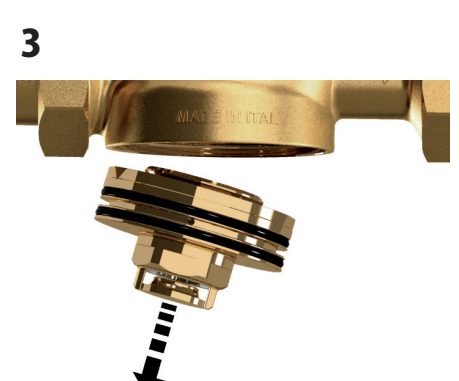

3 Pull the regulator, making sure to not damage the o-rings

Installation and maintenance - Terminator PICV - 85 Series



1. Use conditions

The valve has to be mounted with the arrow in the direction of the flow. Mounting it in the wrong direction may damage the system and the valve itself.

If flow reversal is possible, a non-return valve should be mounted.

Minimum differential pressure above which the valve begins to exercise its regulating effect:

	T85-___-39.6	T85-___-52.8	T85-___-79.3
Start-up ΔP	3.63 PSI	3.63 PSI	5.08 PSI

At 100% preset. See also pages 6-8



2. Flow preset (Requires additional presetting device)

To set the selected flow, follow these steps:

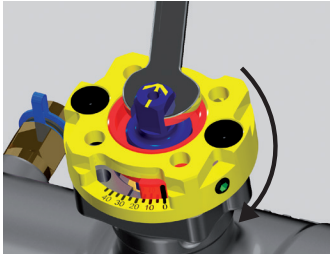

Close the valve

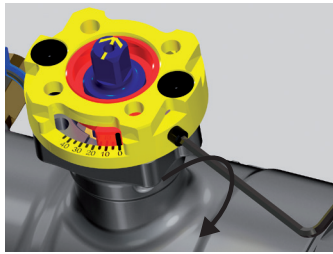

Release locking device

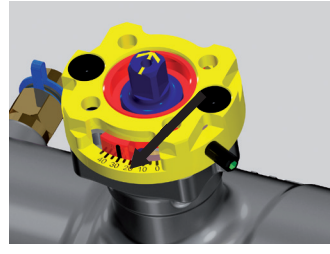

Set maximum flow rate

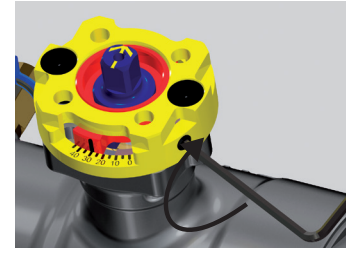

Lock again and re-open the valve

3. Operating control

It is necessary to be sure that the valve is working in the operating range. In order to verify it, measure the differential pressure across the valve, as shown in the picture. If the measured differential pressure is higher than the start-up pressure, the valve is keeping the flow constant at the set value.

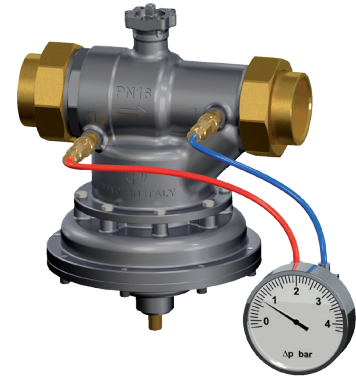

4. Maintenance and cleaning

During valve cleaning operations, use a damp cloth. DO NOT use any detergent or chemical product that may seriously damage or compromise the proper functioning and the reliability of the valve.

5. Flushing and shut off

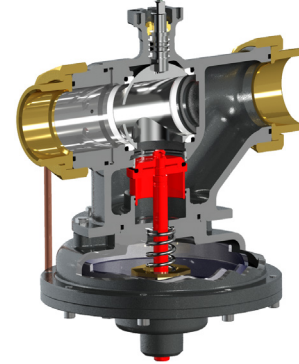
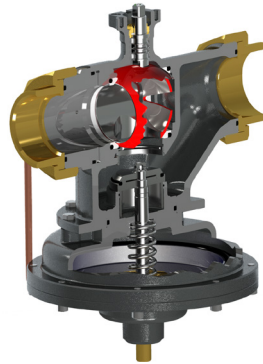
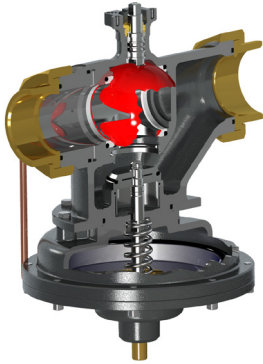

Flushing can be made through the valve by turning the valve 180° or until the arrow on the valve stem is pointing upstream. The differential pressure reducer is now inhibited and no flow limitation occur. Remember to restore the valve in its working position after flushing.

The valve can be closed through the cartridge, should there be the need to do so, by using a 6 mm allen key. In normal working conditions this shut off device must be fully open.

6. Actuator assembly

The valve can be equipped with electromechanical actuators, according to the requirements of the system. Actuators come along with an adaptor for proper mounting on the valve and for proper functioning of the whole device. The mounting pad is made according to ISO 9210 F04, however the valve comes with options to accommodate different actuators.

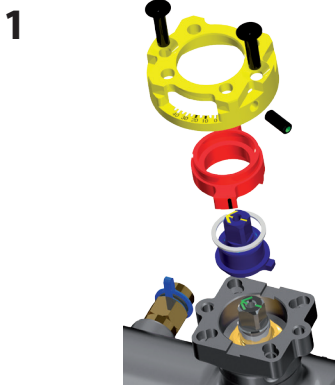

1 Flow presetting device (optional)

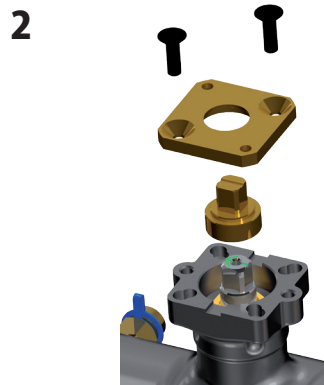

2 Actuator adaptor (optional)



3 Final assembly

Installation and maintenance - Terminator PICV - 94F Series

1. Use conditions

The valve has to be mounted with the arrow in the direction of the flow. Mounting it in the wrong direction may damage the system and the valve itself.

If flow reversal is possible, a non-return valve should be mounted.

Minimum differential pressure above which the valve begins to exercise its regulating effect:

	T94F-FFF-88.1	T94F-GFF-132	T94F-HFF-176	T94F-IFF-242	T94F-JFF-660
Start-up ΔP	4.35 PSI	4.35 PSI	4.35 PSI	4.35 PSI	7.25 PSI



2. Flow preset

The 94F is set up using the Smart Actuator:

When first powered 'GO 0' is displayed on the LCD. Then wait for '0' to appear. Pressing the 'MODE' button for 2 seconds or longer turns to setting mode. You can then choose the detail indication that's suitable for your on-site installations. When in 'set' mode, press the mode button again and you can choose another set mode (set 1 - set 6).

SET1 - Selecting Input / Indication Type

SET2 - Selecting an input tool

SET3 - Min. flow setting

SET4 - Max. flow setting

SET5 - Checking the settings / current values

SET6 - Rotation angle compensation

- 1 Display
- 2 Up button
- 3 Mode button
- 4 Down button



3. Operating control

It is necessary to be sure that the valve is working in the operating range. In order to verify it, measure the differential pressure across the valve, as shown in the picture.

If the measured differential pressure is higher than the start-up pressure, the valve is keeping the flow constant at the set value.

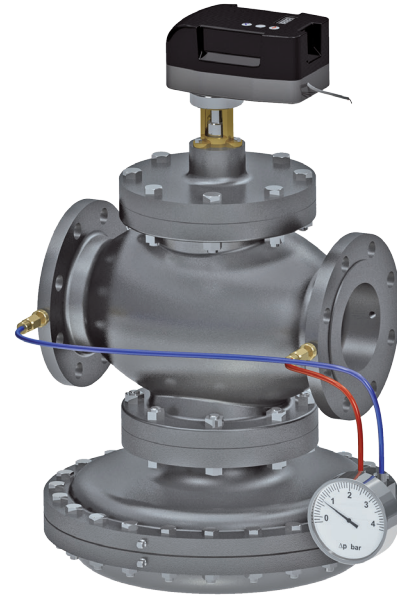

4. Maintenance and cleaning

During valve cleaning operations, use a damp cloth. DO NOT use any detergent or chemical product that may seriously damage or compromise the proper functioning and the reliability of the valve.

5. Manual override

1. Untighten the actuator nut
2. Remove the actuator from the valve
3. Close the valve with a 8 mm wrench

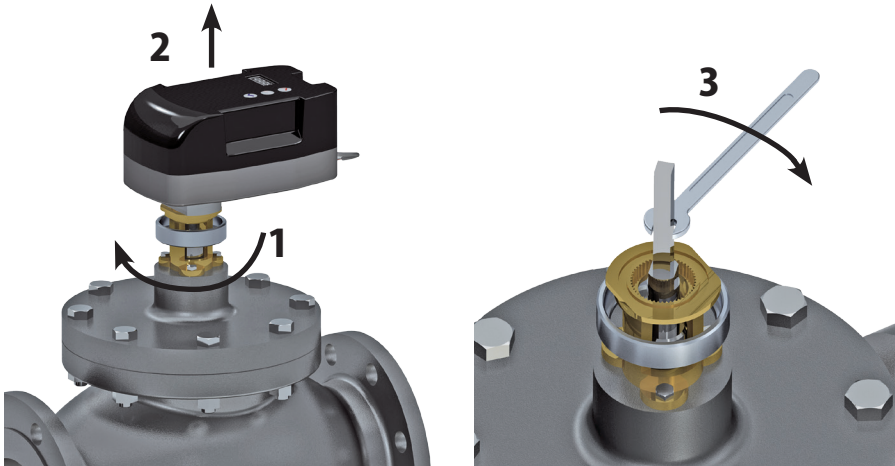

SMART actuators for 94F series



Flow rate can be easily set from the on-board user interface.
Compatible with most used control signals:

Analogue (current or voltage control)
PWM
ON/OFF

4 – 20 mA position feedback signal as default option, for a total remote management.

Manual override available.

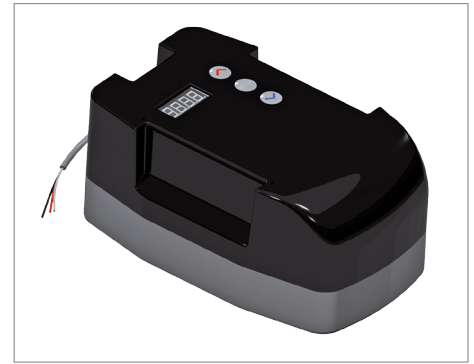

Technical features

Operating duration	170 sec. (Full Open <-> Full Closed)
Emergency operation	Easy removable nut
Control input	PID Control (2-10VDC : installed on external cable of 500Ω resistor) 4 – 20mA (installed on external cable of 500Ω resistor) ON/OFF Control mode (e.g. Thermostat) PWM Control (0.1 ~ 5 sec/20ms or 25 sec/100ms depending on switch setting) Common switch – NPN transistor, SCR, triac or dry contact (max. current 50mA)
Torque	5 Nm
Position feedback	4-20mA or 2-10VDC (installed on external cable of 500Ω resistor)
Ambient temp.	-4°F ~ 149°F
Wire	18AWG
Cover material	Aluminium + Plastic
Protection class	II - IP54

Overall dimensions (in)

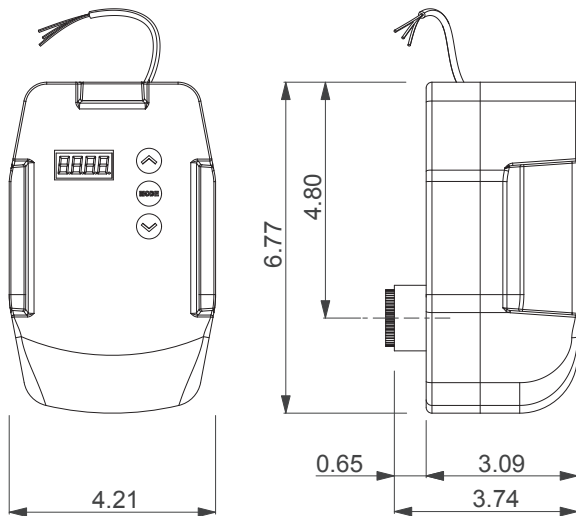

Valve wiring

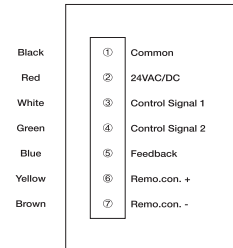

Function	NO.	COLOR							Remarks
		1	2	3	4	5	6	7	
Internal control		Common	24VAC/DC						Power cable : ①②
Voltage control		Common	24VAC/DC	2 – 10VDC					Power cable : ①② Voltage control cable : ①③
Current control		Common	24VAC/DC	2 – 20mA					Power cable : ①② Current control cable : ①③
ON / OFF control		Common	24VAC/DC	24DCV (open) 0V(close)				FEED BACK 4 ~ 20mA	Power cable : ①② ON/OFF control cable : ①③
External Remote control		Common	24VAC/DC					REMO. CON.	Power cable : ①② REMO.CON cable : ⑥⑦
3 POINT FLOATING control		Common	24VAC/DC	drive cw(open) 24VAC/DC	drive ccw(close) 24VAC/DC				Power cable : ①② 3 POINT control cable : ③④
PWM control		Common	24VAC/DC	pwm control signal					Power cable : ①② PWM control cable : ①③

91 TerminatorPICV dimensional data

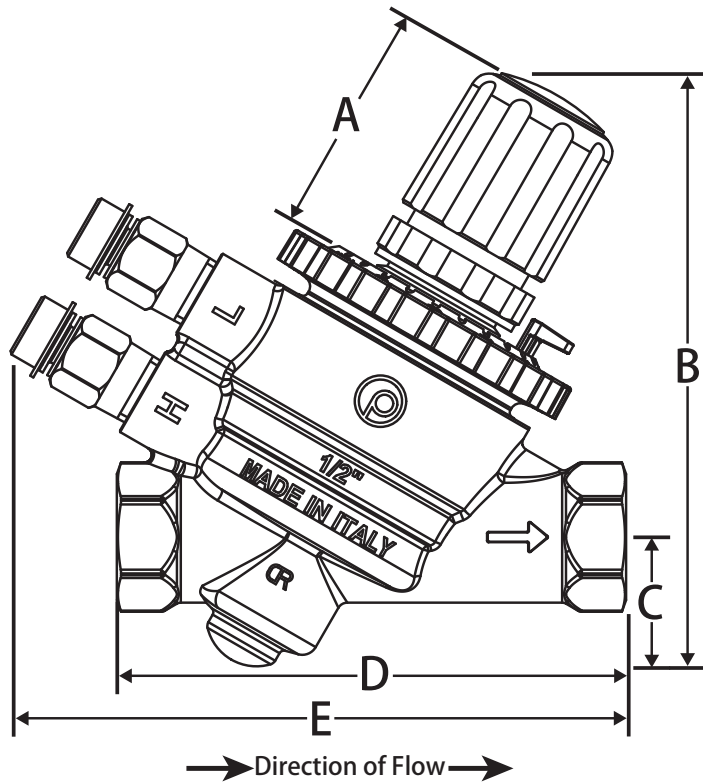

Dimensions					
Size	A	B	C	D	E
1/2"	1.85	4.53	0.98	3.90	4.72
3/4"	1.85	4.53	0.98	4.25	4.72

93 TerminatorPICV dimensional data

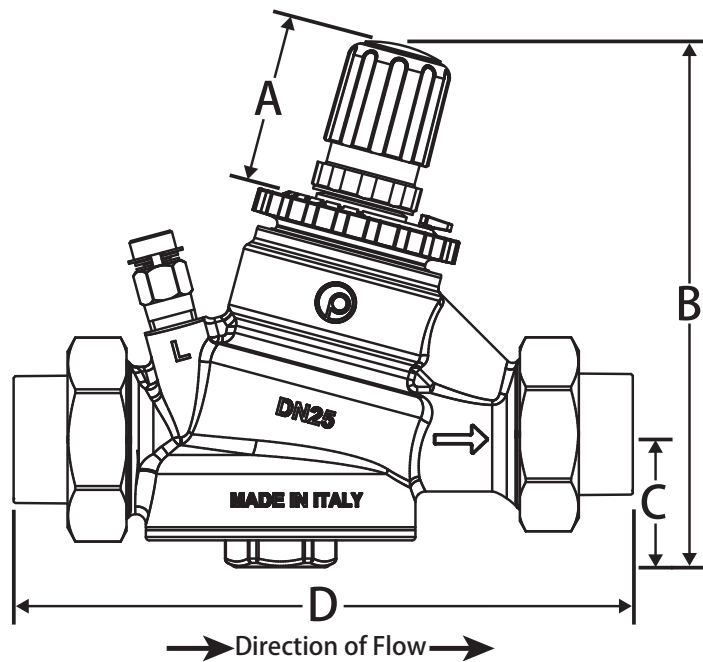

Dimensions				
Size	A	B	C	D
3/4"	1.85	5.98	1.50	5.28
1"	1.85	5.98	1.50	5.28
1 1/4"	1.85	5.98	1.50	5.28

85 TerminatorPICV dimensional data

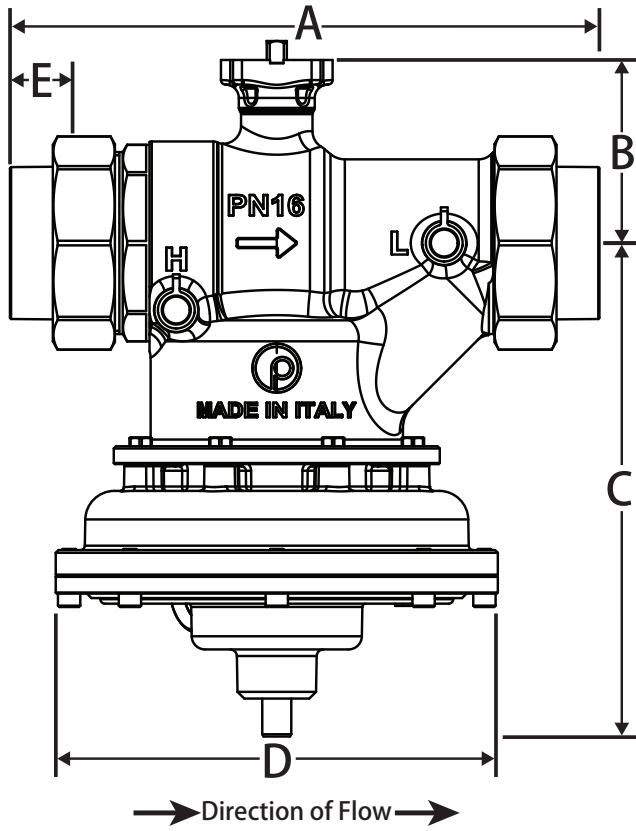

Size	Dimensions				
	A	B	C	D	E
1 1/2"	10.12	3.23	8.70	7.80	0.93
2"	10.39	3.23	8.70	7.80	1.10

94F TerminatorPICV dimensional data

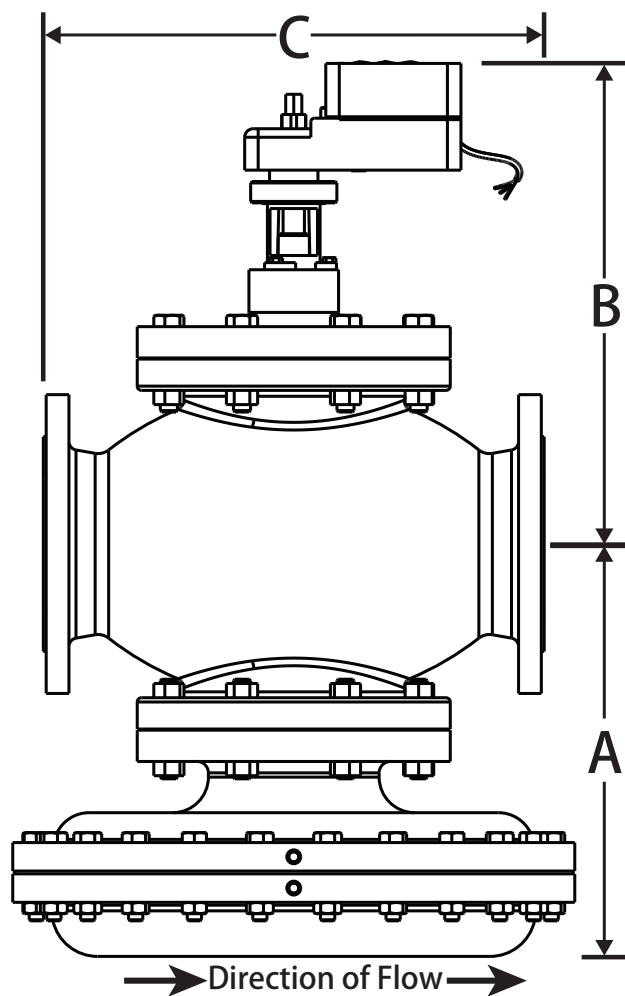

Size	Dimensions		
	A	B	C
2"	8.62	10.51	10.00
2 1/2"	9.21	11.10	10.87
3"	9.41	11.42	11.73
4"	11.22	12.17	13.86
6"	13.78	14.92	17.76

TerminatorPICV shipping weight information

Part	Weight (lbs)
T91-AFF-0.66	1.94
T91-AFF-2.64	1.94
T91-AFF-3.43	1.94
T91-BFF-4.40	2.09
T91-BFF-6.60	2.09
T93-B__-9.68	5.07
T93-B__-11.9	5.07
T93-B__-13.2	5.07
T93-C__-9.68	5.29
T93-C__-11.9	5.29
T93-C__-13.2	5.29
T93-DFF-11.9	5.73

Part	Weight (lbs)
T93-DFF-13.2	5.73
T85-D__-39.6	33.1
T85-E__-39.6	33.7
T85-E__-52.8	33.7
T85-F__-52.8	34.2
T85-F__-79.3	34.2
T85-GFF-79.3	35.3
T94F-FFF-88.1	83.8
T94F-GFF-132	106
T94F-HFF-176	132
T94F-IFF-242	225
T94F-JFF-660	357





7243 Miller Drive • Warren, MI 48092
phone: (586) 268-1220 • fax: (586) 979-8315 • email: csr@jomar.com
www.jomarhydraulics.com